

Data sheet

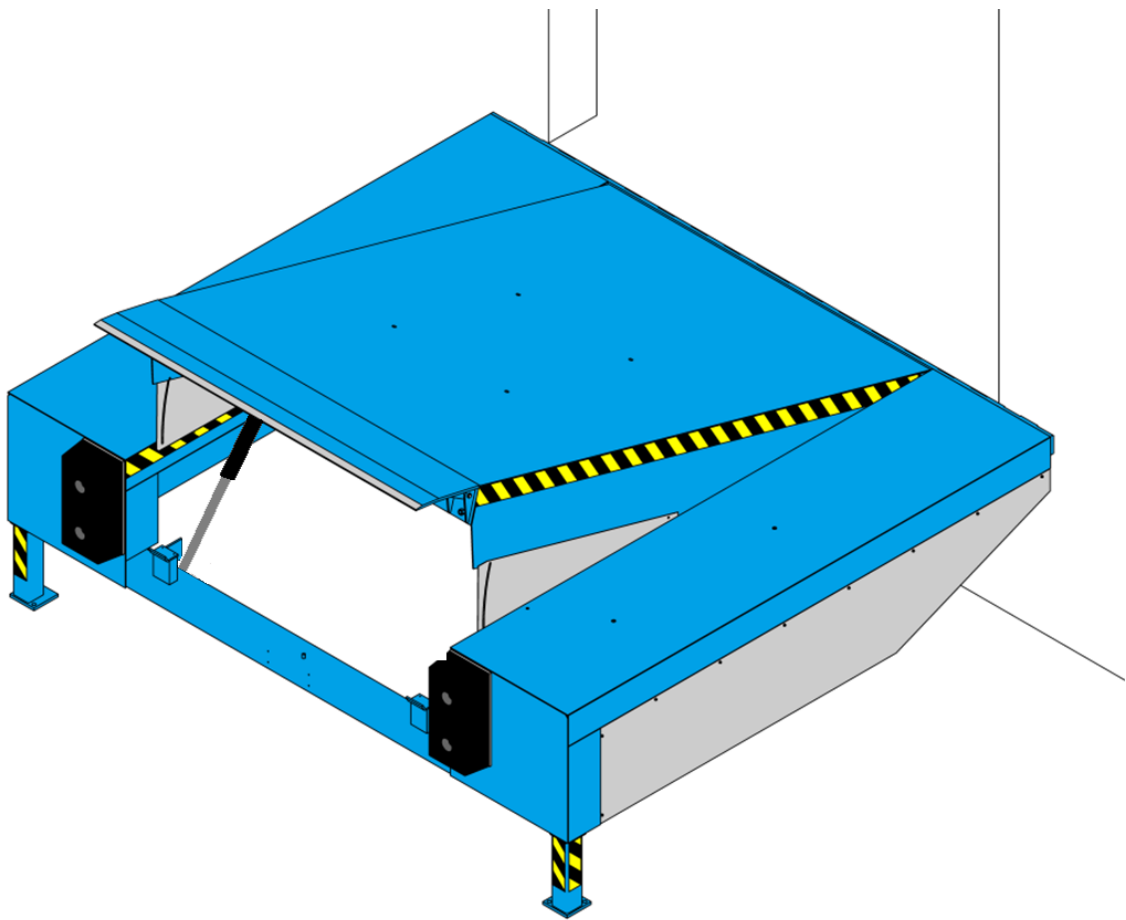

**Table of contents**

1. General information .....	3
1.1 Design features .....	4
1.2 Operating ranges .....	6
2. Hinge lip .....	7
3. Platform .....	9
3.1 Side covers .....	9
3.2 EPDM gasket .....	10
3.3 Anti-slip coating (KVS) .....	11
4. Framing .....	12
4.1 A6 frame .....	12
4.2 A8 frame .....	13
4.3 A6 at an angle to the building .....	14
5. Control system .....	15
6. Leveller selection .....	19

### 1. General information

The PAS leveller with hinge lip is a new design in the wide range of PROMStahl. Excellent quality of this device is the output of 15 years of experience in designing and manufacturing dock levellers. The electrohydraulic PAS type leveller is operated with buttons in the control panel. After lifting the device platform to the highest position, the hinge swings out automatically to rest on the truck bed. During loading operations, the leveller automatically adjusts to changes in the height of the bed (smooth adjustment system).

The PAS leveller is optimal whenever it is necessary to add a loading system to a building. It requires a small amount of preparation and increases effectiveness of the loading and unloading process.

The PROMStahl leveller is a flexible solution and can be positioned in front of the building at different angles (45°, 60°, 75°, 90°, 105°, 120°, 135°). With this, free and sometimes hardly accessible space can be optimally used and efficient loading operations can be carried out. Steel parts of the leveller and platform are available in a hot-dip galvanised and painted version. There is also a leveller with a sealing gate available which forms a complete loading system that can be easily added to the building.

Capacity of the PAS leveller corresponds to the pressure of the axle of a forklift truck given the most unfavourable loading scenario. The PAS leveller of PROMStahl meets all requirements of the latest European standard EN 1398 and bears the CE marking. Additionally, it has been voluntarily certified by the globally-recognised German Technical Inspection Association TÜV and received the GS symbol (Geprüfte Sicherheit) conforming safety of technical devices.

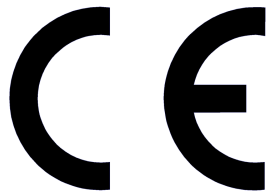

### 1.1 Design features

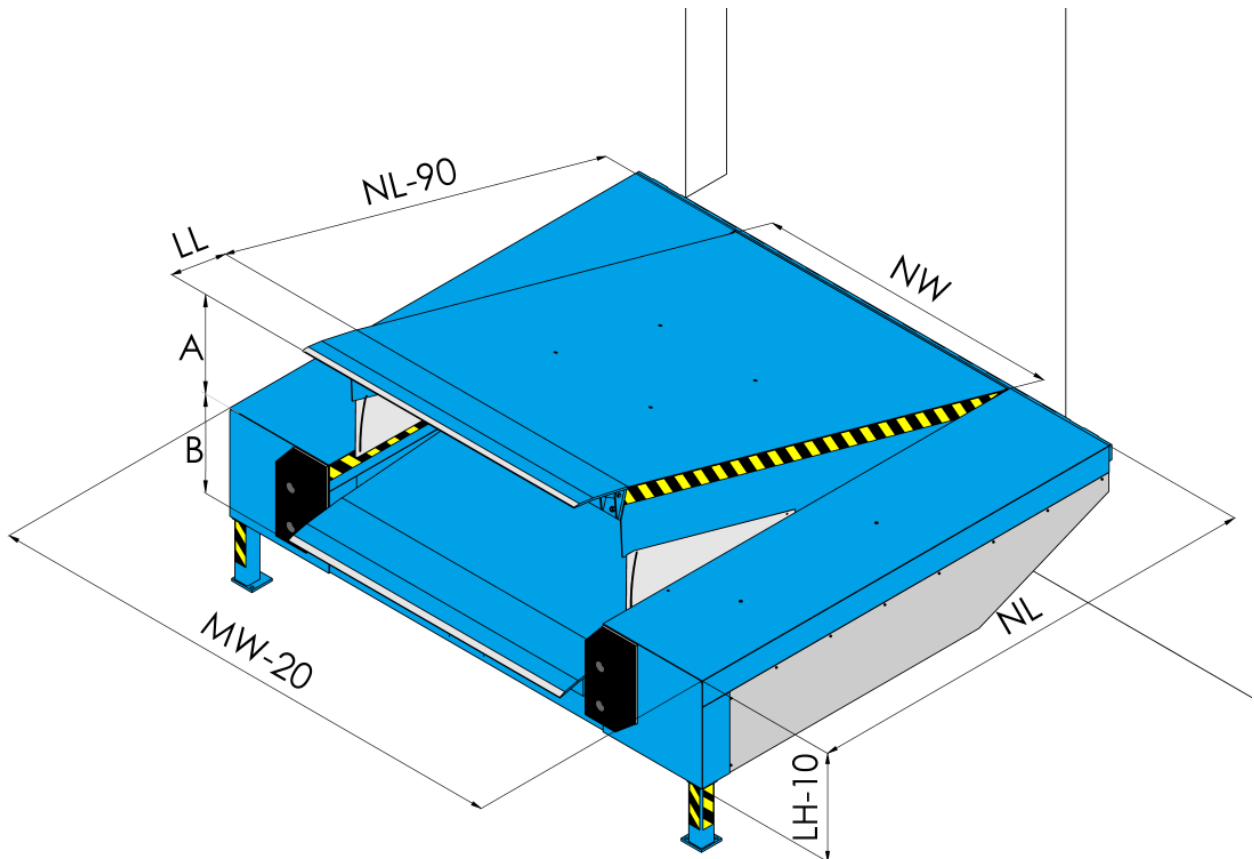

- Nominal lengths (NL): 2000, 2450, 3000, 3500 mm
- Nominal widths (MW): 2000, 2200 mm
- Structure height (LH): 700, 800 mm
- Nominal lip lengths (LL): 400, 500 mm
- Nominal capacity: 6 tonnes (60kN)
- Operating ranges above level (A): 0 – 410 mm
- Operating ranges below level (B): 0 – 360 mm
- Thickness of the upper sheet of the platform: tread plate 6 mm (6/8) or optionally 8 mm (8/10)
- Platform options: anti-slip coating, insulation, EPDM gasket
- Lip sheet thickness: tread plate 13 mm (13/15)
- Lip options: corner chamfering, side segments, straight lip, increased edge bevelling
- Frame: installation by welding (A6) or anchoring with additional two supporting legs (A8)

## Leveller with hinge lip PAS

---

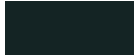
- Standard corrosion protection: sand blasting and painting 80 µm  
 RAL 5010     RAL 7016
- Optional corrosion protection: painting with RAL pallet paints 160 µm, hot-dip galvanising, duplex (hot-dip galvanising and painting)
- Motor power: 0.75 kW
- Power supply: 3~400 V, N, PE / 50Hz / 16A
- Control system tightness degree: IP65
- Standard functions of the control system: one control button, main switch, door sensor connector
- Optional functions of the control system: automatic rest position return button, LCD, wheel lock control, indicator light control, air sealing control, manual air sealing control, sealing blind control, PROM door control, vehicle sensor control, door release signal
- Hydraulic unit: compact hydraulic unit installed under the leveller, two actuators to lift the leveller equipped with safety valves, lip swing actuator
- Hydraulic oils: standard oil (-20°C to +60°C), low temperature oil (-30°C to +60°C), bio oil (-20°C to +60°C)

### 1.2 Operating ranges

NL	LH	LL	A	B
1750	700	400	250	325
2000	700		290	340
2450	700		345	317
2750	700		390	330
3000	700		430	330
3500	800		520	350
1750	700	500	130	370
2000	700		190	360
2450	700		255	335
2750	700		290	330
3000	700		320	330
3500	800		410	360

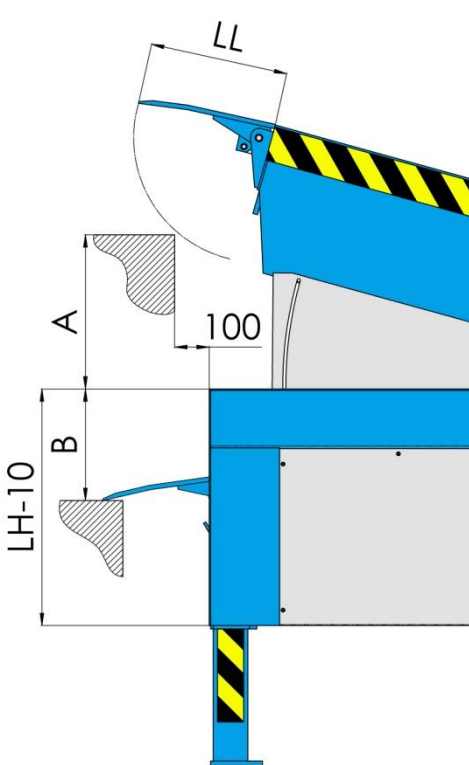

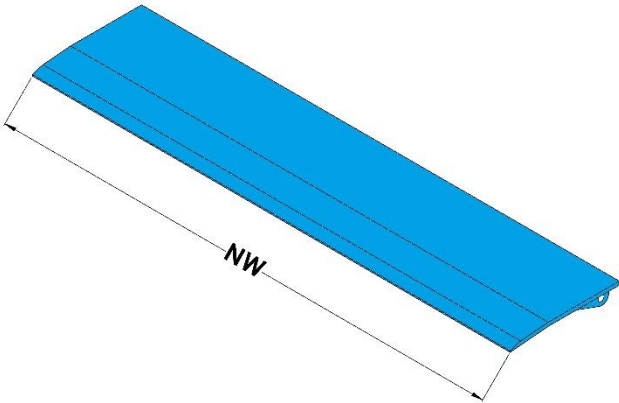
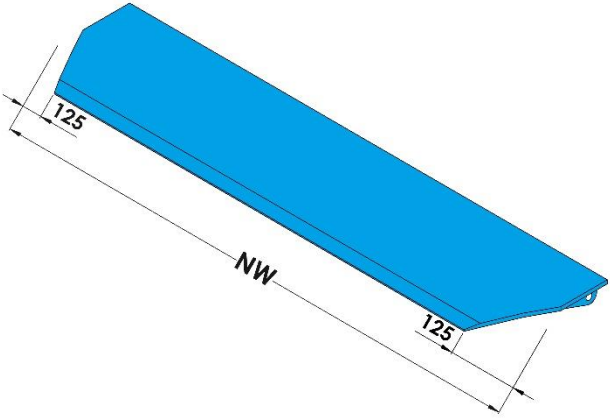
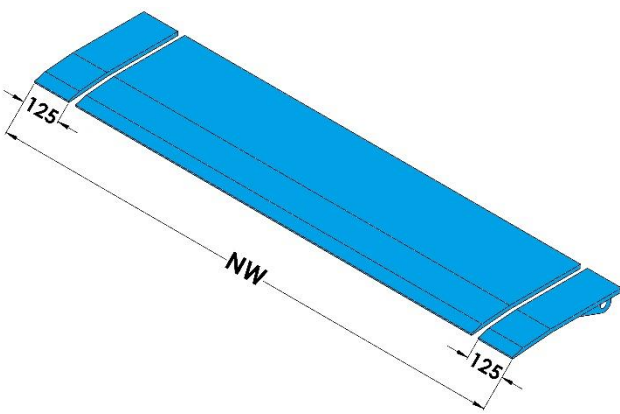

### 2. Hinge lip

The lip of the PAS-type leveller is made of high quality tread plate with thickness of 13 mm (13/15) and equipped with a special, solid, contamination-resistant and almost maintenance-free system of hinges. The structure of the resting supports ensures a safe distance between the lip and the frame bar which prevents potential hand injuries. There is a wide range of optional lip designs available:

<p>Standard lip</p>		<p>Standard solution. Suitable for most loading operations of typical size vehicles.</p>
<p>Chamfered lip</p>		<p>Lip symmetrically cut on both sides by 125 mm. It makes loading easier and limits the risk of damaging a vehicle in case of inappropriate docking.</p>
<p>Lip with segments</p>		<p>Lip with automatically retracted (at contact with the vehicle's sideboard) side segments (1500 mm on each side) for docking narrower vehicles or vehicles not attached to the dock with 100% accuracy. Recommended for NW=2250.</p>

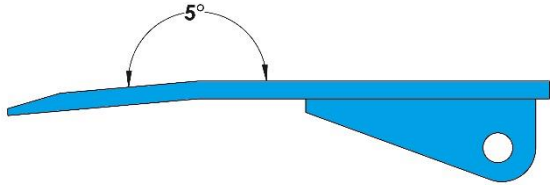
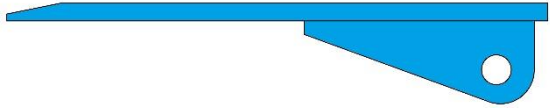
## Leveller with hinge lip PAS

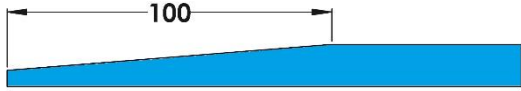
Bent lip		Standard solution. It ensures good work ergonomics when the vehicle bed is both below and above the docking floor level.
Straight lip		Solution for better work ergonomics when the vehicle bed is below the docking floor level.
Bevelling 40 mm		Standard solution. It ensures good ergonomics for loading devices with large and soft wheels.
Bevelling 100 mm		Solution improving work ergonomics, especially for loading devices with small and hard wheels.

### 3. Platform

The platform of the PAS-type leveller with load capacity of 60kN is made of high quality tread plate with thickness of 6 mm (6/8) and is intended to be used with standard, four-wheel forklift trucks with pneumatic wheels or so-called super elastic wheels. Optionally, the sheet thickness can be increased to 8 mm (8/10) to use the leveller with hard wheel devices such as electric pallet trucks. The upper sheet is reinforced from the bottom with special binders ensuring torsional flexibility of the platform. This ensures adhesion of the vehicle along the entire width to the bed surface even at transverse tilts of the vehicle equal to 10% of the nominal width of the device. Connection between the platform and the frame is ensured by means of a special, solid, contamination-resistant and almost maintenance-free system of hinges.

#### 3.1 Side covers

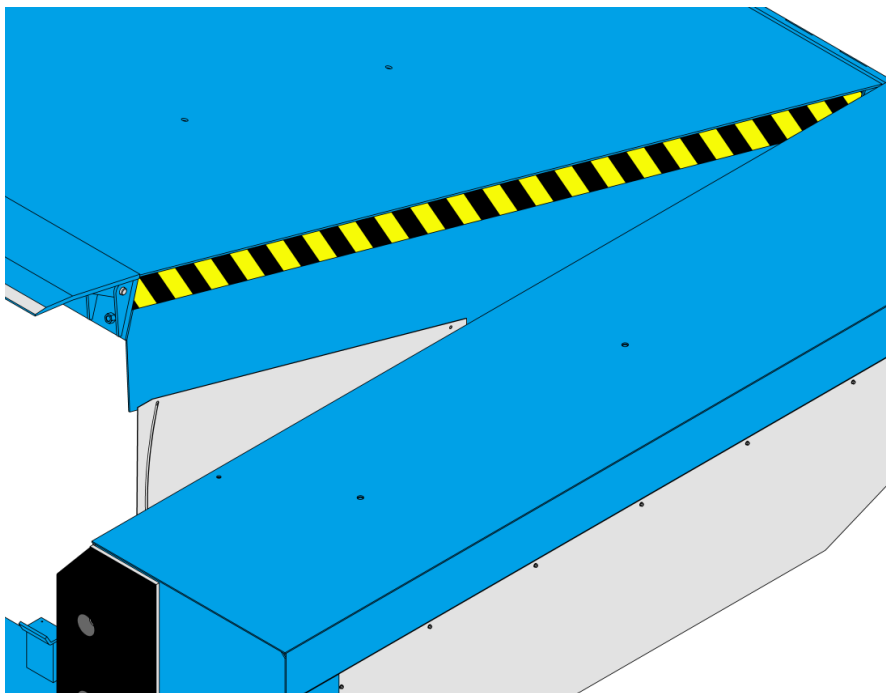

The PAS-type leveller is equipped with rigid, movable side covers preventing accidents related to dangerous limb injuries which could occur when leaving the platform.

### 3.2 EPDM seal

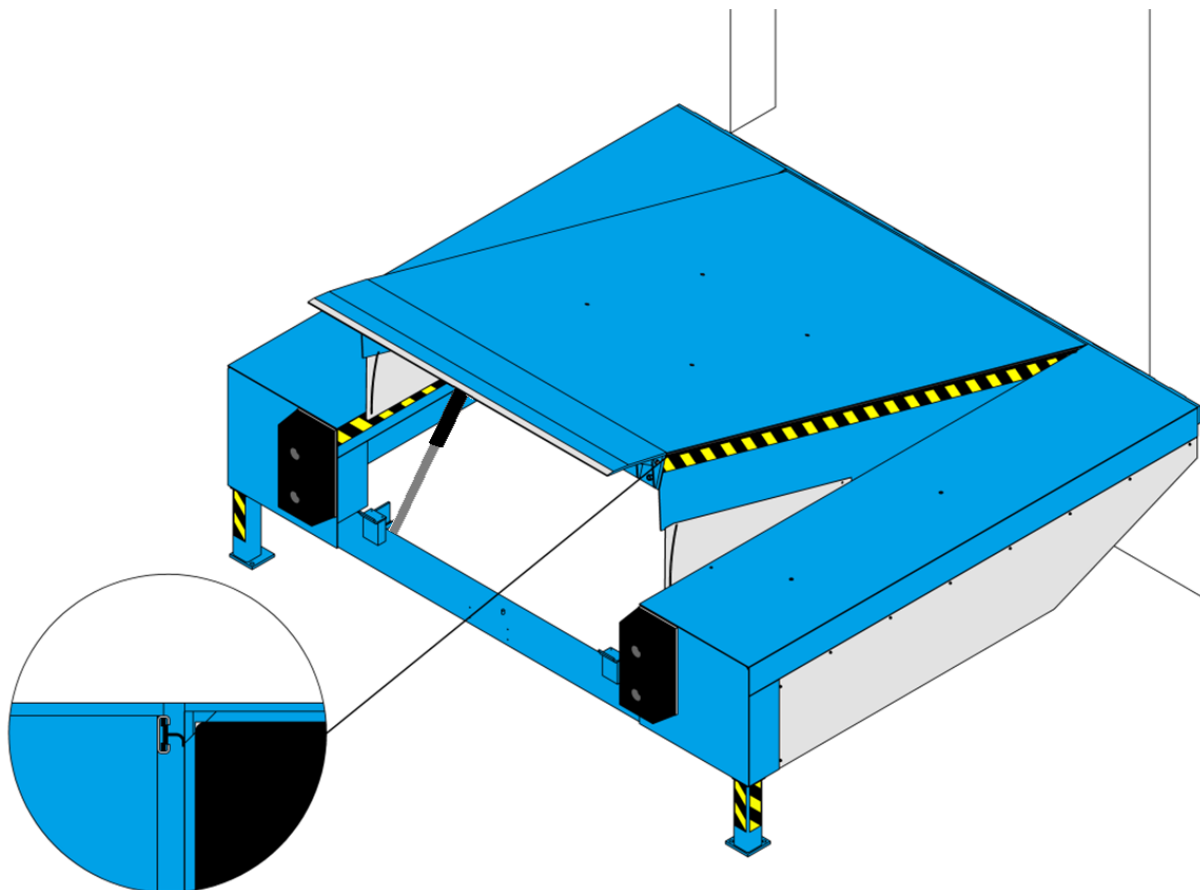

In order to limit air infiltration through the dock leveller it can be optionally fitted with a gasket between the platform and the framing. This improves working conditions in the warehouse and ensures power saving.

### 3.3 Anti-slip coating (KVS)

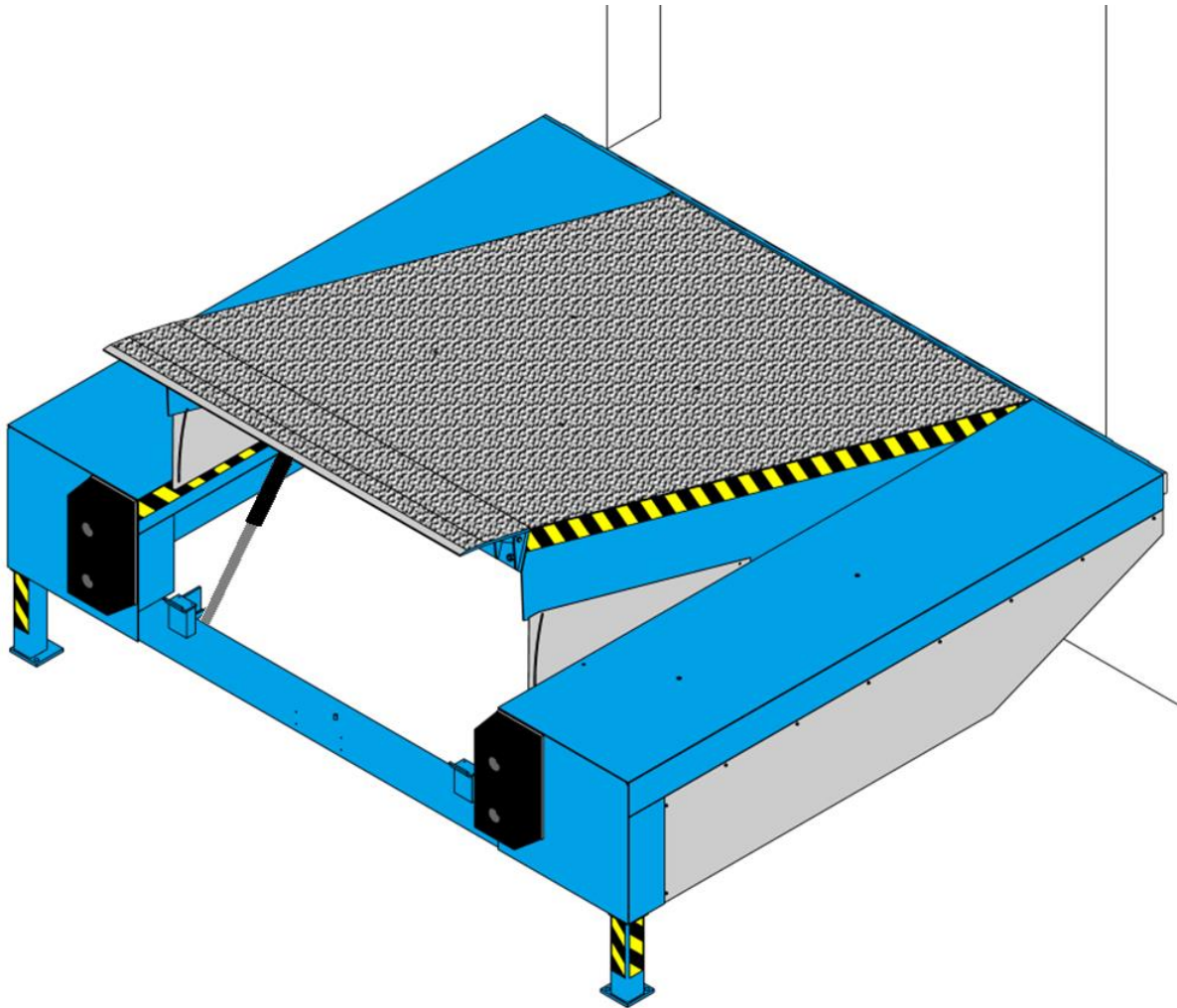

The platform and the lip of the PAS-type dock leveller can be optionally finished with special anti-slip coating with thickness of about 4 mm, consisting of flexible polyurethane layer resistant to pressure and most chemicals, as well as of fine basalt aggregate. Such combination guarantees greater ergonomics and safety of work through much better traction for a forklift truck and reduction of the intensity of sound generated during reloading operations.

### 4. Framing

The framing provides connection of the leveller with the building, supports it in rest position and constitutes a base for mounting a loading gate. The PAS-type leveller comes in two versions of framing for each installation requirement ensuring so-called undercut for docking vehicles with a lift. The leveller can also be equipped with an additional platform for positioning a device at an angle ( $45^\circ$ ,  $60^\circ$ ,  $75^\circ$ ,  $90^\circ$ ,  $105^\circ$ ,  $120^\circ$ ,  $135^\circ$ ) in front of the building.

#### 4.1 A6 framing

The PAS leveller A6 framing is welded directly to the building edge fitting and supported in the front part on two steel supporting legs. This solution ensures easy and quick installation, however, it requires building edge fittings of a proper load capacity.

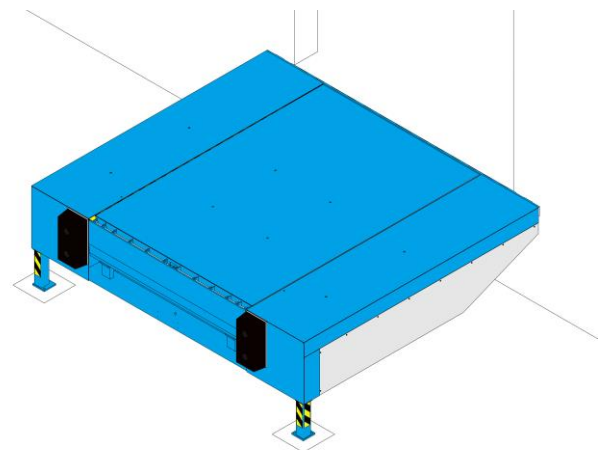
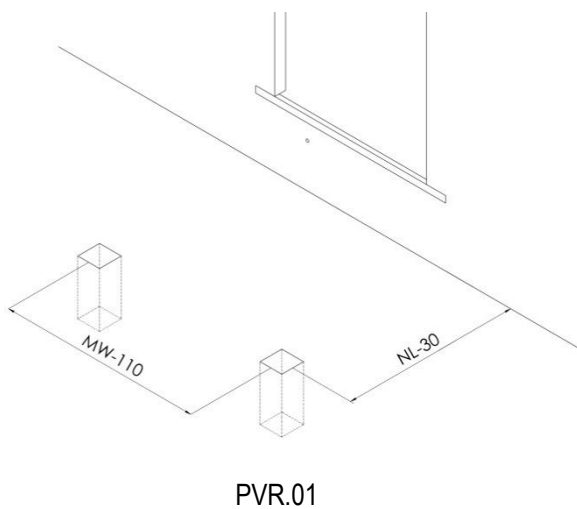

### 4.2 A8 framing

The PAS leveller framing is anchored directly to the building wall and supported in the front and rear part on four steel supporting legs. This solution ensures easy and quick installation for buildings not equipped with door opening edge fittings. Instead of modifying the existing facility, an additional foundation has to be laid.

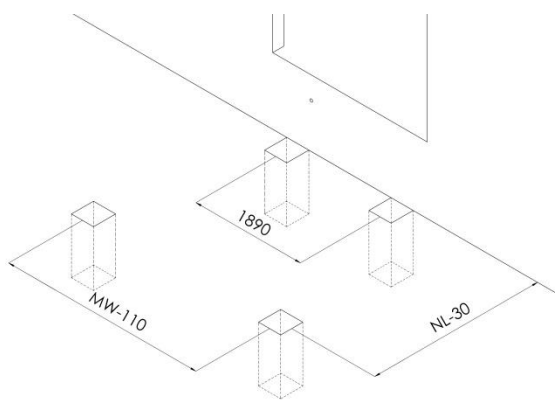

PVR.08

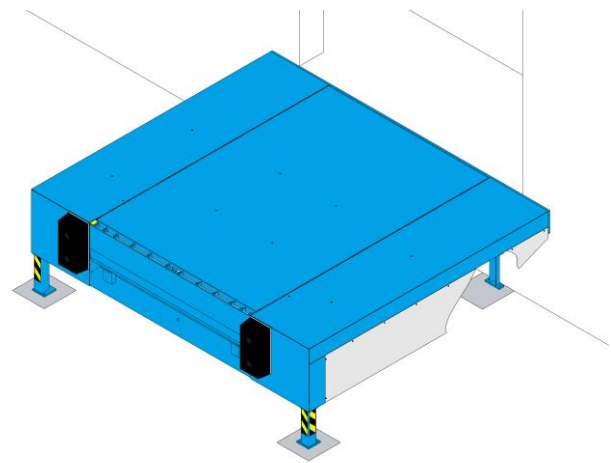

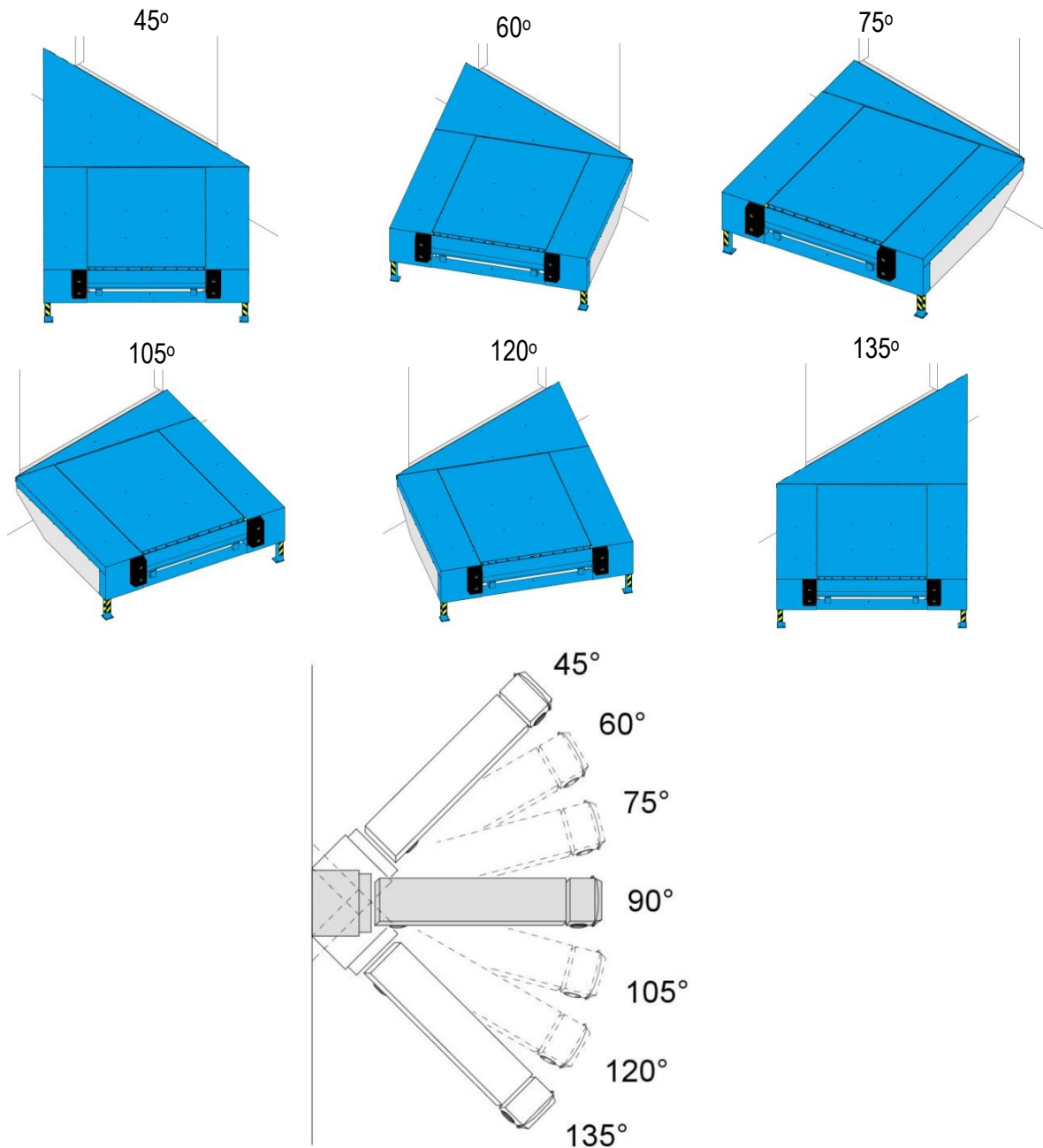

### 4.3 A6 at an angle to the building

An additional platform for positioning the PAS platform in front of the building at different angles (45°, 60°, 75°, 90°, 105°, 120°, 135°). With this, free and sometimes hardly accessible space can be optimally used and efficient loading operations can be carried out.



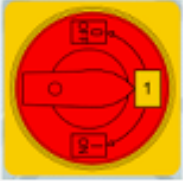

### 5. Control system

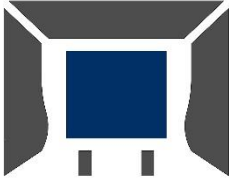
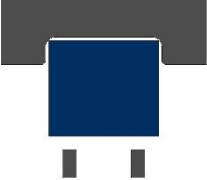
The control system of the PAS-type dock leveller manufactured by PROMStahl is available in two versions: standard and equipped with a series of auxiliary options supporting operation of additional devices, accessories and sensors.

	<p style="text-align: center;"><b>Main switch</b></p> <p>It is used for switching the device on/off every day and serves as an emergency switch. Switching the main switch stops all movements of the device.</p>
	<p style="text-align: center;"><b>Control button</b></p> <p>For lifting the platform, swinging the lip to the working position and causing the dock leveller to return to home position.</p>
	<p style="text-align: center;"><b>Automatic return button</b></p> <p>Brief push of this button causes the dock leveller to automatically return from working to home position.</p>
	<p style="text-align: center;"><b>Air sealing control</b></p> <p>This button allows you to control the air sealing manually. It is also possible to connect sealing in an automatic way ensured by the dock leveller or door.</p>
	<p style="text-align: center;"><b>Sealing blind control</b></p> <p>The controller makes it possible to connect the sealing blind motor and additional buttons are used for lifting and lowering the blind.</p>

## Leveller with hinge lip PAS

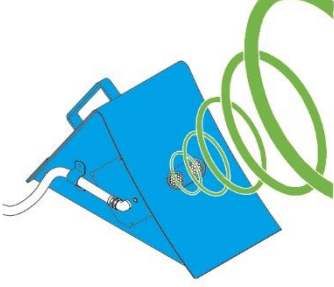
	<p style="text-align: center;"><b>PROM door cont</b></p> <p>Additional buttons for controlling the functions of the PROM door from the control panel of the dock leveller.</p>
	<p style="text-align: center;"><b>LCD</b></p> <p>Display with additional servicing and diagnostic functions.</p>
<p style="text-align: center;"><b>The control system of the dock leveller allows you to connect other safety accessories.</b></p>	
	<p style="text-align: center;"><b>Indicator lights</b></p> <p>Connection of indicator lights (internal and external) for better safety of works.</p>
	<p style="text-align: center;"><b>Wheel lock sensor</b></p> <p>A wheel lock makes it impossible to activate the dock leveller before securing the docked vehicle (it prevents the vehicle from moving away during loading operations).</p>

## Leveller with hinge lip PAS

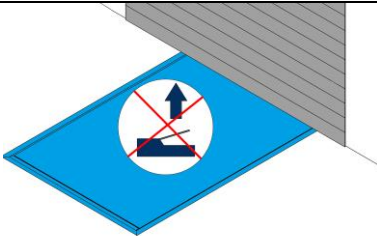
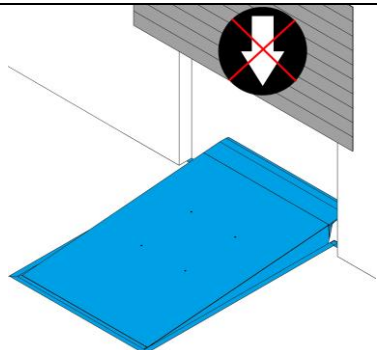
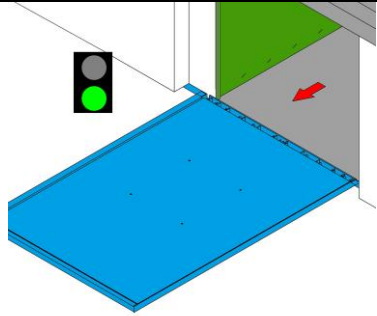
	<p style="text-align: center;"><b>Door sensor</b></p> <p>The door sensor makes it impossible to activate the dock leveller before opening the door (it prevents door and leveller collision).</p>
	<p style="text-align: center;"><b>Door release signal</b></p> <p>An additional connector with a door lock signal when the dock leveller is not in its home position. It prevents door and leveller collision.</p>
	<p style="text-align: center;"><b>Vehicle sensor</b></p> <p>The controller allows you to connect an optical sensor detecting a docked vehicle.</p>

## Leveller with hinge lip PAS

	BASIC type controller	STANDARD type controllers			
		PBES 1MV 06	PBES 1MV 07	PBES 1MV 08	PBES 1MV 09
Automatic return	<b>✘</b>	<b>✓</b>	<b>✓</b>	<b>✓</b>	<b>✓</b>
Air sealing control - automatic	<b>✘</b>	<b>✓</b>	<b>✓</b>	<b>✓</b>	<b>✓</b>
Air sealing control – automatic + button	<b>✘</b>	<b>✘</b>	<b>✘</b>	<b>✓</b>	<b>✓</b>
Sealing blind control	<b>✘</b>	<b>✓</b>	<b>✓</b>	<b>✓</b>	<b>✓</b>
Door control buttons	<b>✘</b>	<b>✓</b>	<b>✘</b>	<b>✘</b>	<b>✓</b>
Indicator light control	<b>✘</b>	<b>✓</b>	<b>✓</b>	<b>✓</b>	<b>✓</b>
Door sensor	<b>✓</b>	<b>✓</b>	<b>✓</b>	<b>✓</b>	<b>✓</b>
Wheel lock sensor	<b>✓</b>	<b>✓</b>	<b>✓</b>	<b>✓</b>	<b>✓</b>
Vehicle sensor	<b>✘</b>	<b>✓</b>	<b>✓</b>	<b>✓</b>	<b>✓</b>
Leveller position sensor	<b>✘</b>	<b>✓</b>	<b>✓</b>	<b>✓</b>	<b>✓</b>

✓ - support

✘ - no support

### 6. Leveller selection

#### Nominal capacity

This is the maximum loading value resulting from the total weight of objects moved on the dock leveller. According to the guidelines of EN 1398 standard this value takes into consideration dynamic effects caused by the operated forklift truck. The total weight of the used forklift truck with accessories, the driver and the load must not exceed the nominal loading capacity of the dock leveller.

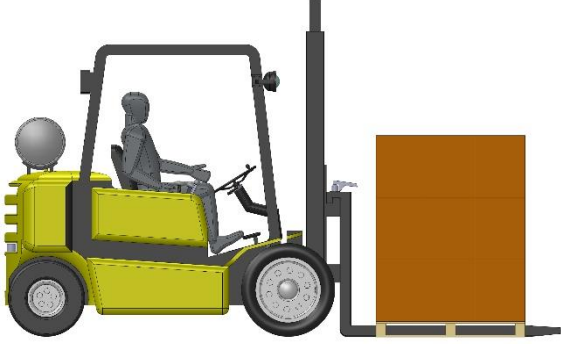
	Forklift truck	3600 kg
	Transported goods	1500 kg
	Operator	100 kg
	Total weight	$\Sigma=5200 \text{ kg} < 6000\text{kg}$ $= 60 \text{ kN}$

#### Wheel pressure

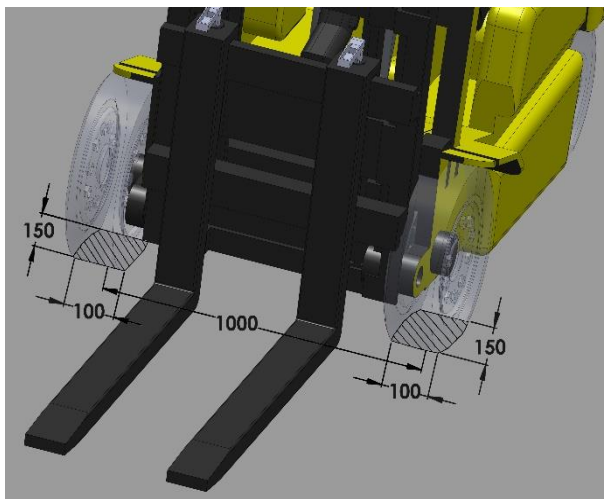



According to the guidelines of EN 1398 standard, the basic version of the dock leveller was designed for works with forklift trucks with pneumatic or super elastic wheels with tread resembling two 150 mm x 100 mm rectangles. For devices with hard wheels (e.g. electric pallet trucks), please consult a representative of PROMStahl to select the best solution for your docking station.

## Leveller with hinge lip PAS

### Nominal length

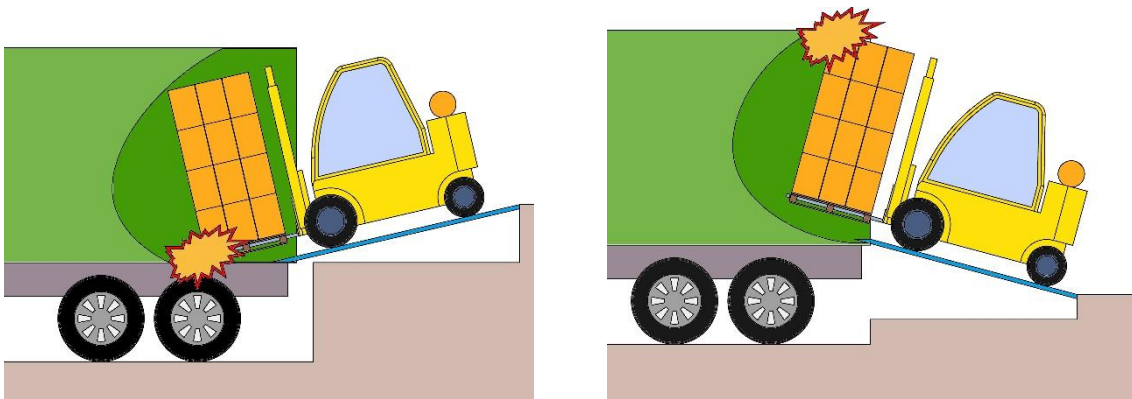
Nominal length of the applied dock leveller and maximum height differences between the warehouse floor and the vehicle bed determine the slope of the platform in its working position. The slope value should not exceed maximum recommended values for given loading devices. The maximum permissible value recommended by EN 1398 is 12.5%. Too much inclination may damage transported goods, cause the docking device to be hanged and decrease the durability of the dock leveller (greater travel dynamics).

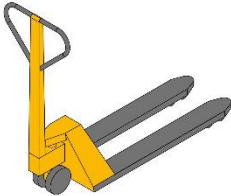
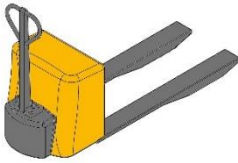

Docking device		Recommended maximum slope
Small hand-operated devices, e.g. pallet truck		3 ÷ 5 %
Small electrically-driven devices, e.g. electric pallet truck		7 %
Electric forklift trucks		10 %

## Leveller with hinge lip PAS

<b>Engine-powered forklift trucks</b>		12.5 % (15 %)
---------------------------------------	---	---------------

Estimated heights of trucks:

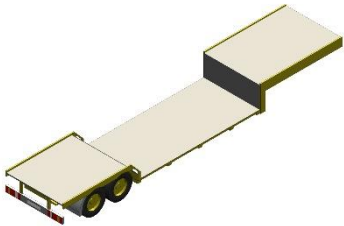
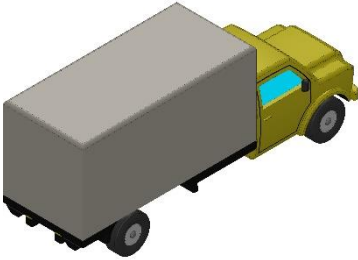
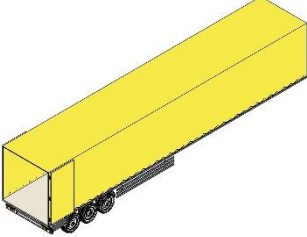
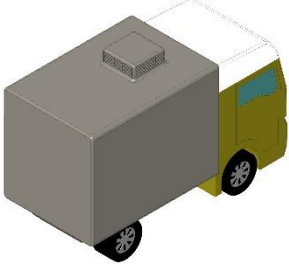
	Type of vehicle	Bed height [mm]
<b>Low-loading semi-trailers</b>		600 - 1000
<b>Commercial vehicles</b>		1000 - 1200
<b>Semi-trailers</b>		1100 - 1400
<b>Refrigerated trucks</b>		1300 - 1500

## Leveller with hinge lip PAS

<p><b>Containers</b></p>		<p>1200 - 1600</p>
--------------------------	---	--------------------

Example:

Docking device: electric forklift truck (maximum slope: 7%)

Vehicle bed height: 1100 mm – 1400 mm

Building floor height: 1200 mm

Maximum height difference to be compensated: 200 mm

$200 \text{ mm} / 7\% = 2857 \text{ mm} \rightarrow$  the minimum nominal length NL = 3000 mm has to be taken

### Nominal width

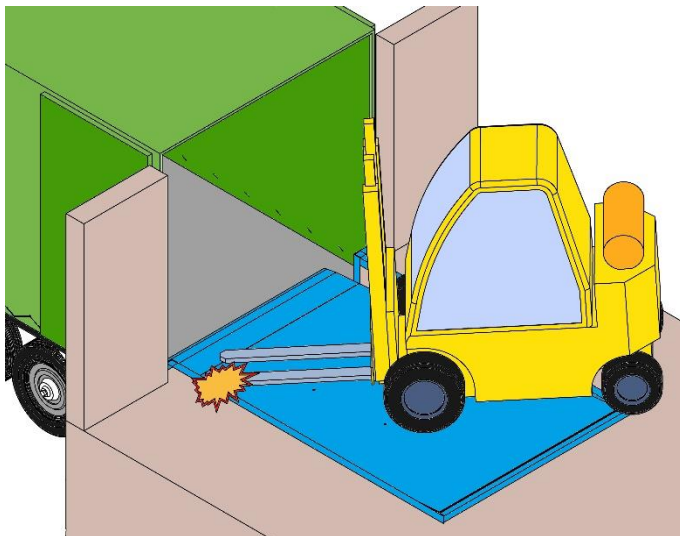

Pursuant to the guidelines of EN 1398 standard, the minimum width of a dock leveller is related to the width of used docking devices and should be greater by at least 700 mm than their tread. Failure to meet this condition may compromise the loading safety (when reloading above the floor) or limit the efficiency (when reloading below the floor).

Example:

Tread of the widest docking device is 1200 mm

$1200 \text{ mm} + 700 \text{ mm} = 1900 \text{ mm} \rightarrow$  the minimum nominal width NW = 2000 mm has to be taken

The maximum width of a dock leveller is related to the width of the vehicle bed and docking accuracy. When determining the maximum width of the vehicle, take into account the width of the bed of the narrowest vehicle and reduce it by the recommended docking inaccuracy tolerance (recommended 150 mm per side). The maximum width value can be increased by side segments of the lip.

## Leveller with hinge lip PAS

### Example:

The bed of the narrowest vehicle has 2450 mm in width.

$2500 \text{ mm} - 2 \cdot 150 \text{ mm} = 2100 \text{ mm}$  → the maximum nominal widths  $NW = 2100 \text{ mm}$  for standard lip or 2250 mm for lip with side segments (2 x 125 mm) are to be taken.

### Maximum height of the dock leveller

The maximum height of the dock leveller results from maintaining a tail-lift recess (undercut). This is a place under the dock leveller of the following recommended minimum dimensions: 3000 mm x 350 mm. The tail-lift recess is necessary for docking vehicles with a lift.

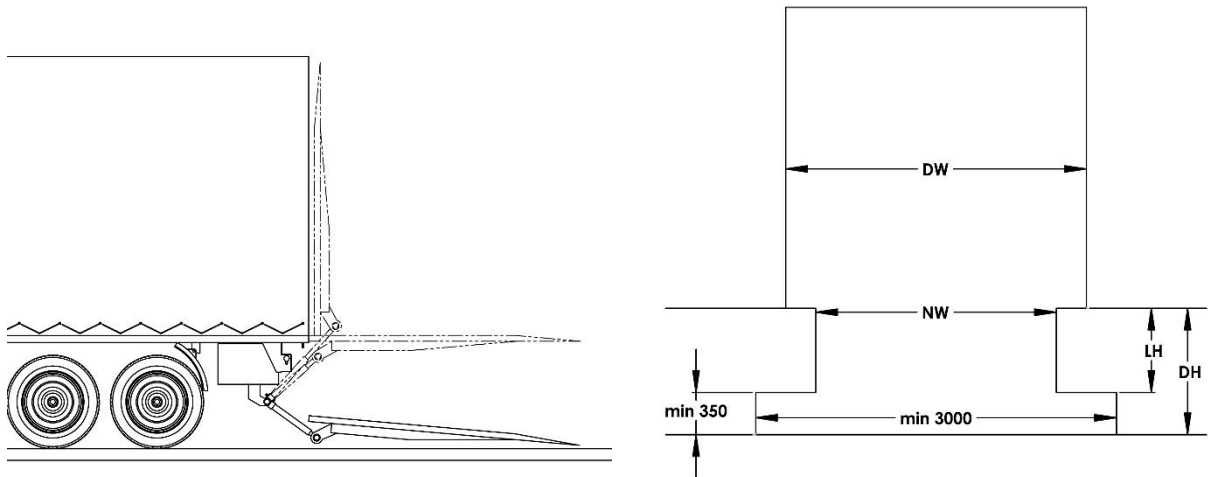

NW – nominal width of the dock leveller

LH – leveller height

DH – dock height

DW – door width

Taking the leveller height away from the dock height gives the height of the tail-lift recess.

### Example:

Dock height: 1100 mm

Leveller height: 700 mm

$1100 - 700 = 400 > 350$  → the minimum height of the tail-lift recess is ensured.