

Data sheet

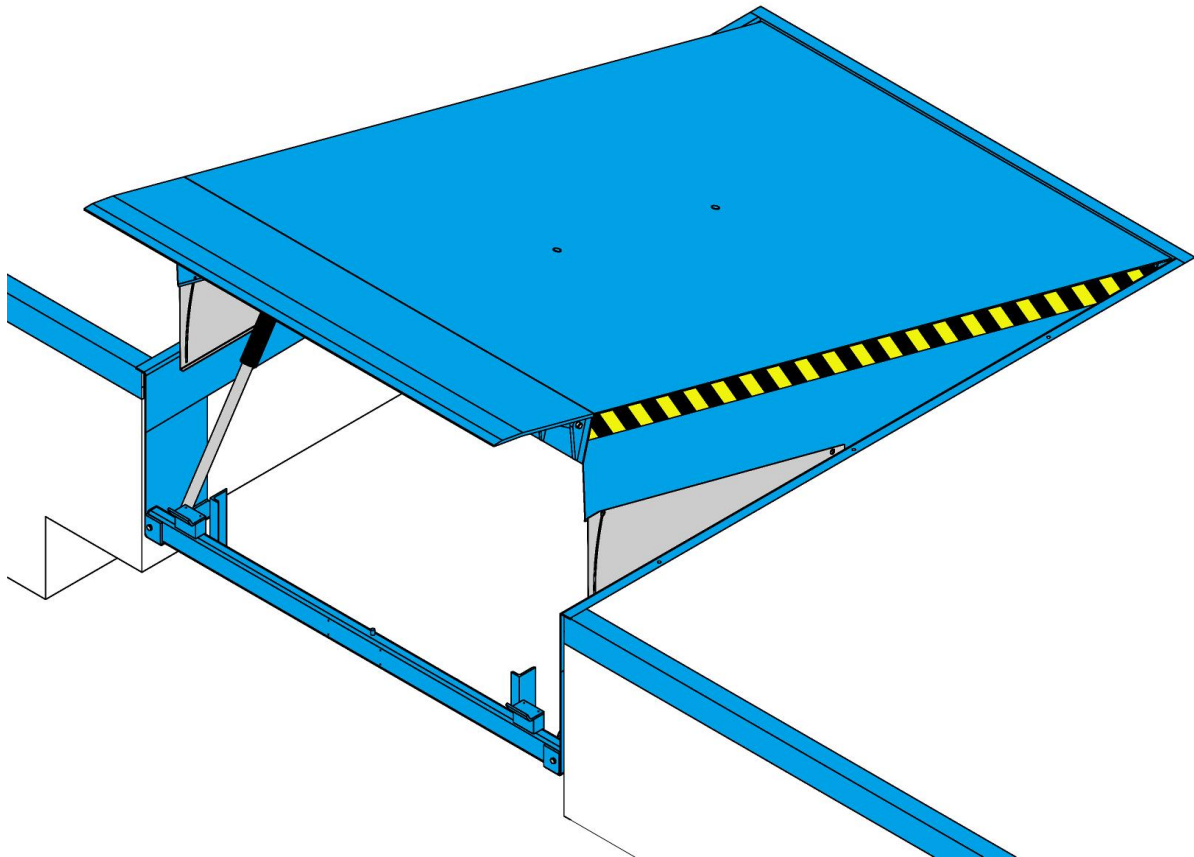

Table of contents

1.	General information.....	3
1.1	Design features.....	4
1.2	Operating range.....	5
2.	Hinge lip.....	6
3.	Platform.....	8
3.1	Side covers.....	8
3.2	EPDM gasket.....	9
3.3	Front screen.....	9
3.4	Anti-slip coating (KVS).....	10
4.	Framing.....	11
4.1	T-frame.....	11
4.2	W-frame.....	12
4.3	F-frame.....	13
4.4	O-frame.....	14
4.5	B-frame.....	15
4.6	Pit-frame.....	16
4.7	SMD-frame.....	17
5.	Control system.....	18
6.	Leveller selection.....	22

1. General information

The PS-type dock leveller with hinge lip is a result of many years of experience in manufacture of levelling systems and the output of a highly qualified research and development team. Use of higher-strength steel allowed for reduction of the leveller weight, while maintaining its great strength and durability. During loading and unloading operations the leveller automatically adapts to the height fluctuations of the vehicle bed (smooth adjustment system) and perfect torsional flexibility ensures safe and comfort loading of goods. The open hinging system reduced the risk of contamination to minimum, thus excessive wear of hinge areas. Owing to structural changes, maintenance of movable components and durability of the same has been simplified and increased accordingly. Innovative changes in the platform extension slide components were introduced to make operation of the platform smooth for a long time. The control system can be extended with support of many useful functions such as control of the indicator lights, control of the air sealing, PROM door control, vehicle sensor operation and other. The frame design has been upgraded, increasing significantly its durability as well as the service life of the entire platform. The PS-type dock leveller is equipped with a frame and constitutes a compact unit to be installed in a prepared pit in one step. With a wide range of available frames, it is possible to select a structural solution perfect for each investor. The load capacity of the dock leveller has been calculated taking into consideration worst case loading situations. The PROMStahl PS-type dock leveller meets all the requirements of the most recent European EN 1398 standard and has the CE marking.



1.1 Design features

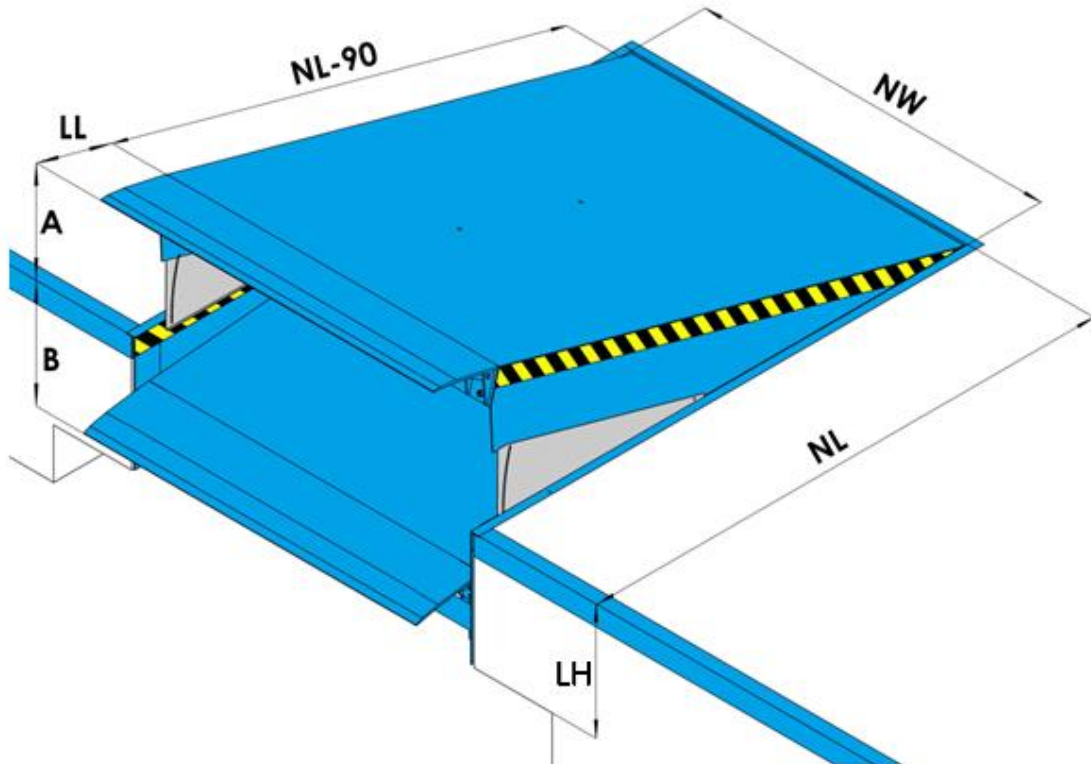

- Nominal lengths (NL): 1750, 2000, 2500, 2750, 3000, 3500, 4000, 4500 mm
- Nominal widths (NW): 1750, 2000, 2100, 2200, 2250, 2400 mm
- Leveller height (LH): 600, 700, 800, 900 mm
- Nominal lip lengths (LL): 400, 500 mm
- Nominal capacity: 6 ton (60kN)
- Operating ranges above level: 0 – 570 mm
- Operating ranges below level: 0 – 350 mm
- Thickness of the upper sheet of the platform: tread plate 6 mm (6/8) or optionally 8 mm (8/10)
- Platform options: anti-slip coating, insulation, EPDM gasket
- Lip sheet thickness: tread plate 13 mm (13/15)
- Lip options: corner chamfering, fold-down segments, FALL-GUARD interlock, straight lip, increased edge bevelling
- Frame: installation by concreting (T, B, T-Spezial) or welding (W, F, O, Pit, SMD)
- Standard corrosion protection: sand blasting and painting 80 µm

 RAL 5010

 RAL 7016

Dock leveller with hinge lip PS

- Optional corrosion protection: painting with RAL pallet paints 160 µm, hot-dip galvanizing, duplex (hot-dip galvanizing and painting)
- Motor power: 0.75 kW
- Power supply: 3~400 V, N, PE / 50Hz / 16A
- Control system tightness degree: IP65
- Standard functions of the control system: one control button, main switch, door sensor connector
- Optional functions of the control system: LCD, indicator light control, air sealing automatic control, air sealing manual control, sealing blind control, PROM door control, vehicle sensor control, door release signal, mechanical wheel lock control
- Hydraulic unit: compact hydraulic unit installed under the platform, two actuators to lift the platform equipped with safety valves, lip swing actuator
- Hydraulic oil:
 - Standard oil (-20°C to +60°C),
 - Low-temperature oil (-30°C to +60°C),
 - Bio oil (-20°C to +60°C)

1.2 Operating range

NL	BH	LL	A	B
1750	700	400	250	325
2000			290	350
2500			380	315
2750			390	310
3000			450	305
3500			800	380
4000	900	500	570	300
4500	900		530	290
1750	700		185	345
2000	700		190	340
2500	700	260	325	
2750	700	275	320	
3000	700	305	315	
3500	800	310	310	
4000	900	460	300	
4500	900	430	300	
2000	600	400	290	270
2500			360	260
2750			330	260
3000			305	255

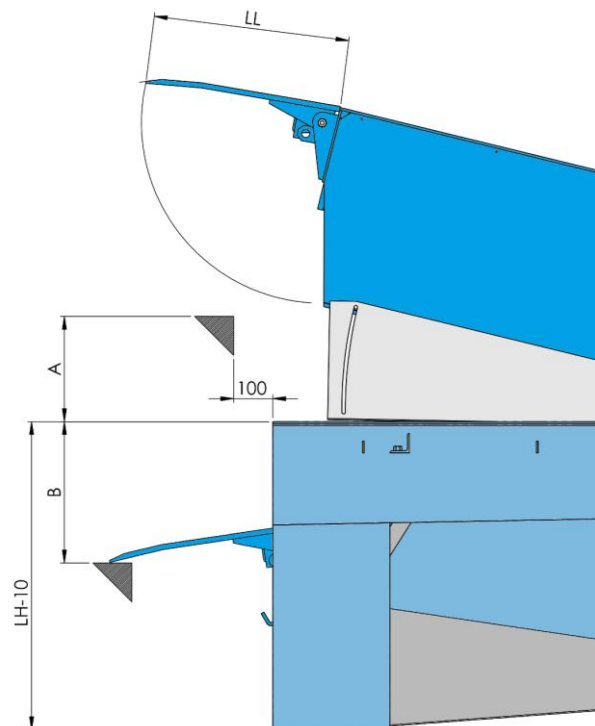

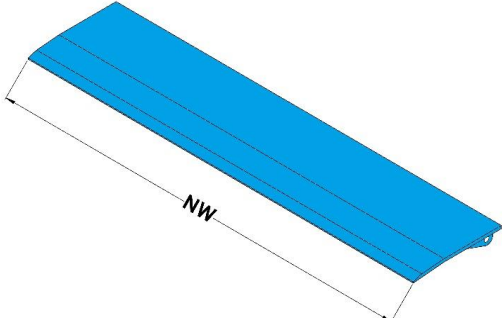
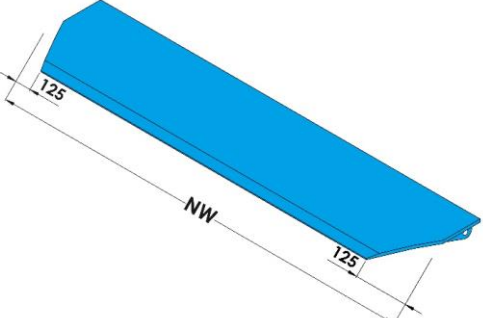
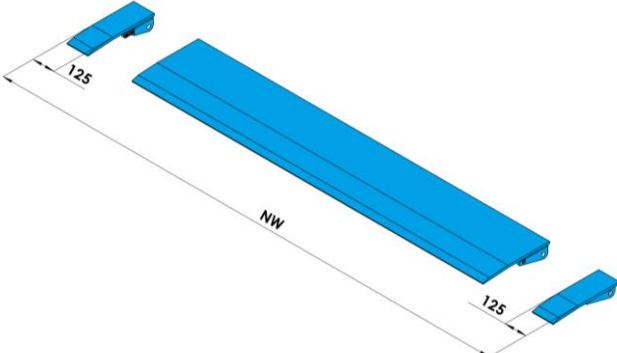

2. Hinge lip

The lip of the PS-type dock leveller is made of high quality tread plate with thickness of 13 mm (13/15) and equipped with a special, solid, contamination-resistant and almost maintenance-free system of hinges. The structure of the resting supports ensures a safe distance between the lip and the frame bar which prevents potential hand injuries. There is a wide range of optional lip designs available:

Standard lip		<p>Standard solution. Suitable for most loading operations of typical size vehicles.</p>
Bevelled lip		<p>Lip symmetrically cut on both sides by 125 mm. It makes loading easier and limits the risk of damaging a vehicle in case of inappropriate docking.</p>
Fold-down segments		<p>Lip consists of a central element and two side elements (located on the left and right hand side). The side elements fold down independently of the central element. The lip width is reduced by 125 mm on each side so that vehicles with narrow beds can be also loaded and unloaded. When the lip returns to its rest position, the side elements are automatically locked with the central element so that the central element and the side elements are lifted together during the subsequent swing-out process.</p>

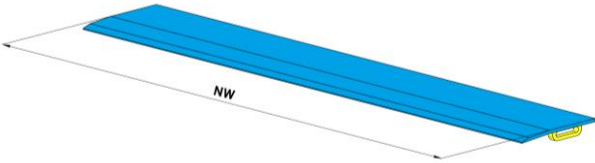
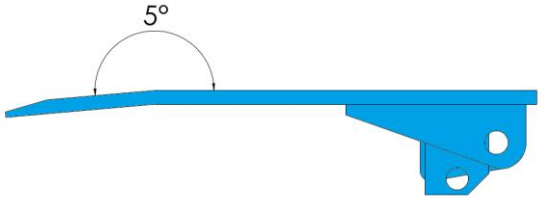
Dock leveller with hinge lip PS

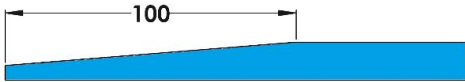
FALL-GUARD interlock lip		<p>This lip, at platform resting position, projects at a height of 90 mm, which is an obstacle, and at the same time protection against falling down the forklift from the ramp through the dock gate.</p>
Bend lip		<p>Standard solution. It ensures good work ergonomics when the vehicle deck is both below and above the docking floor level.</p>
Straight lip		<p>Solution for better work ergonomics when the vehicle deck is below the docking floor level.</p>
Bevelling 40 mm		<p>Standard solution. It ensures good ergonomics for loading devices with large and soft wheels.</p>
Bevelling 100 mm		<p>Solution improving work ergonomics, especially for loading devices with small and hard wheels.</p>

3. Platform

The platform of the PS-type dock leveller with load capacity of 60kN is made of high quality tread plate with thickness of 6 mm (6/8) and is intended to be used with standard, four-wheel forklift trucks with pneumatic wheels or so-called super elastic wheels. Optionally, the sheet thickness can be increased to 8 mm (8/10) to use the leveller with hard wheel devices such as electric pallet trucks. The upper sheet is reinforced from the bottom with special binders ensuring torsional flexibility of the platform. This ensures adhesion of the vehicle along the entire width to the deck surface even at transverse tilts of the vehicle equal to 10% of the nominal width of the device. Connection between the platform and the frame is ensured by means of a special, solid, contamination-resistant and almost maintenance-free system of hinges.

3.1 Side covers

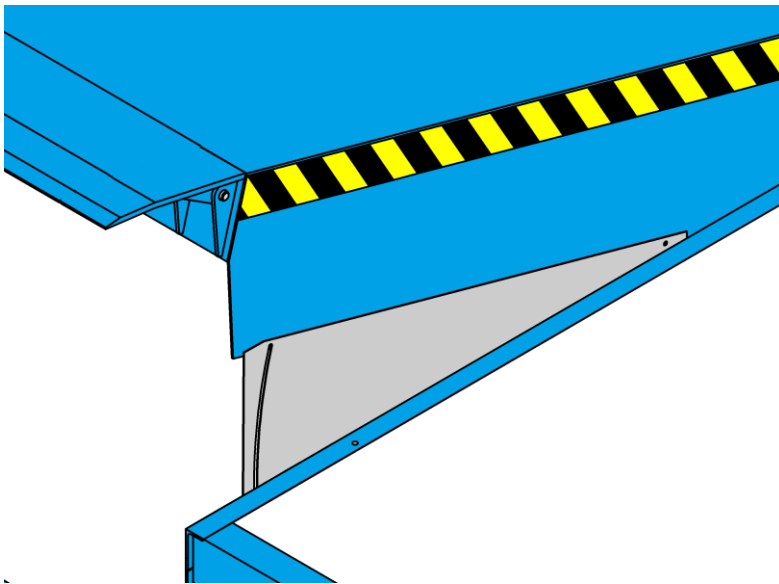

The PS-type dock leveller is equipped with rigid, movable or fixed side covers preventing accidents related to dangerous limb injuries which could occur when leaving the platform.

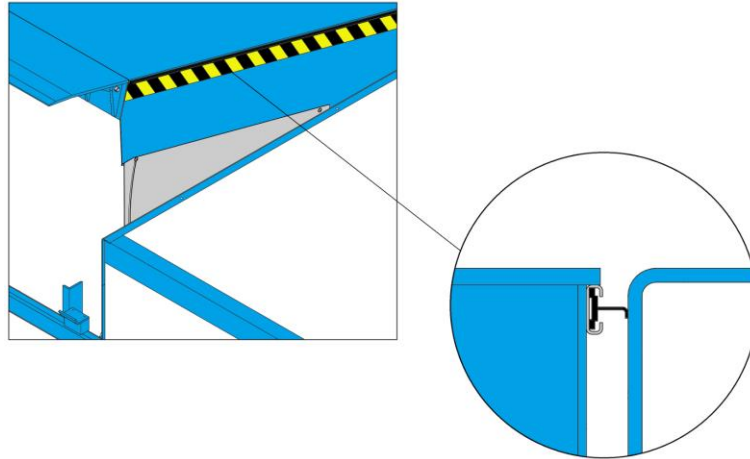
3.2 EPDM gasket

In order to limit air infiltration through the dock leveller it can be optionally fitted with a gasket between the platform and the framing. This improves working conditions in the warehouse and ensures power saving.

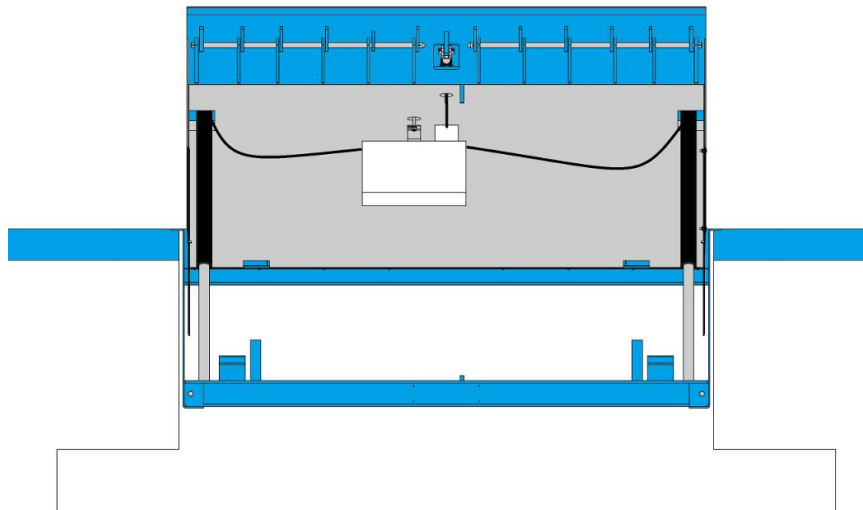
3.3 Front screen

Optional insulation of the platform ensured by panels with thickness of 40 to 60 mm reduces heat losses and the intensity of sounds transmitted by the device. It is recommended to apply insulation in combination with an EPDM gasket.

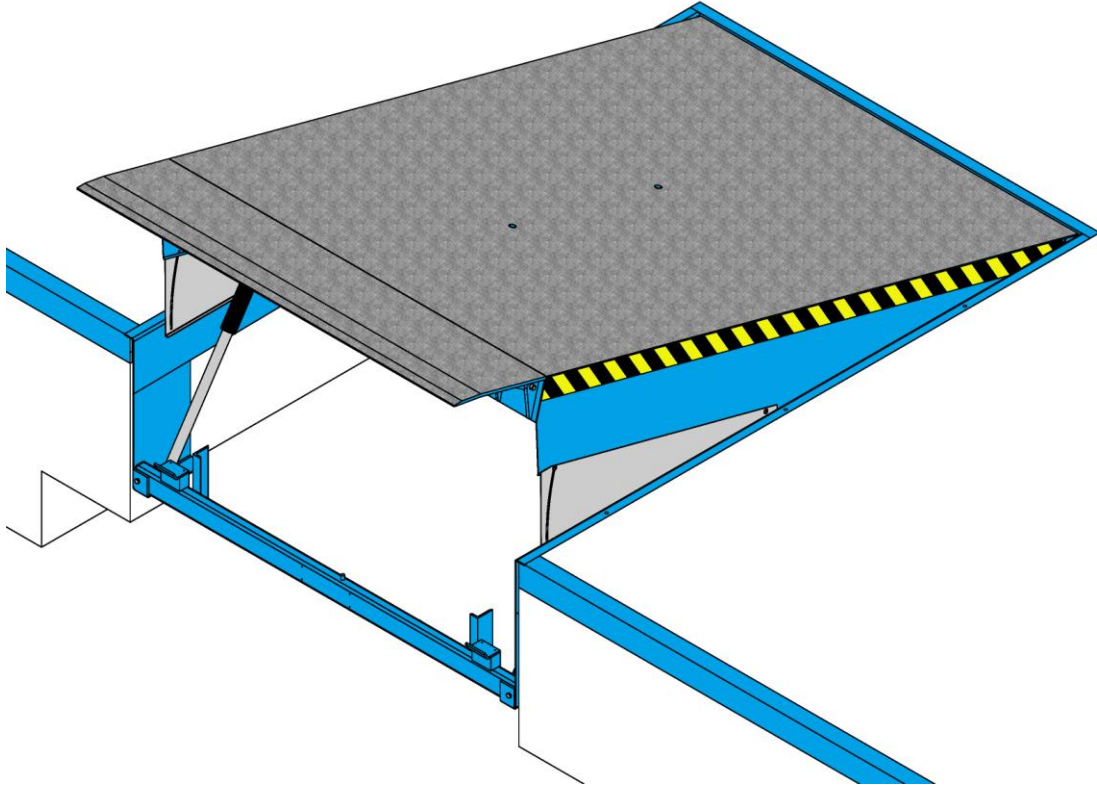
3.4 Anti-slip coating (KVS)

The platform and the lip of the PS-type dock leveller can be optionally finished with special anti-slip coating with thickness of about 4 mm, consisting of flexible polyurethane layer resistant to pressure and most chemicals, as well as of fine basalt aggregate. Such combination guarantees greater ergonomics and safety of work through much better traction for a forklift truck and reduction of the intensity of sound generated during reloading operations.

4. Framing

The framing provides connection of the dock leveller with the building and supports it in rest position. The PS-type dock leveller comes with a wide range of framing for each installation requirement ensuring so-called undercut for docking vehicles with a lift.

4.1 T-frame

The dock leveller framing is filled with concrete. The frame around the leveller is equipped with a 200-mm wall serving as a small formwork. This significantly facilitates concrete works. Quick and clean installation in one step is an advantage of this solution.

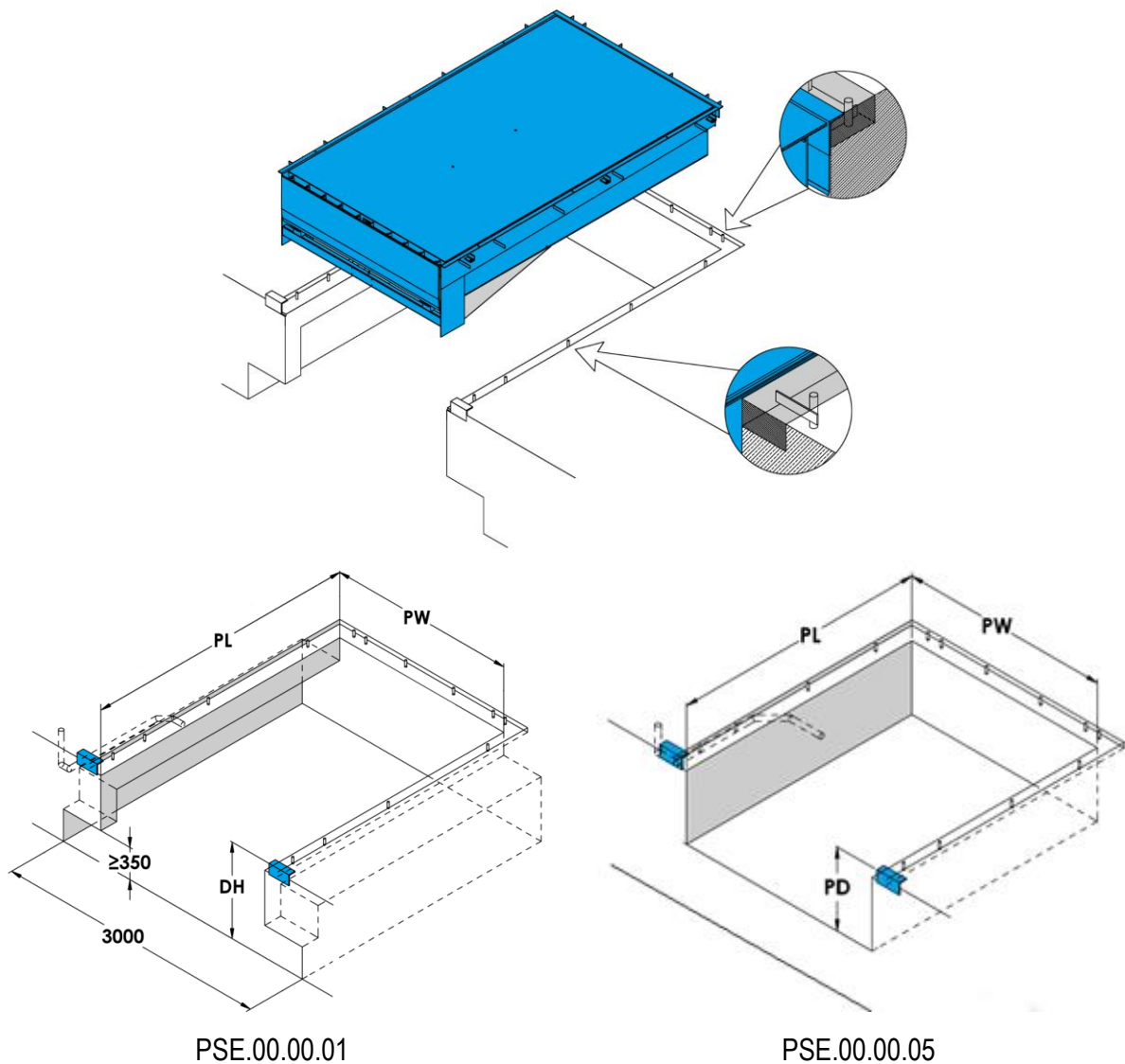

Dock leveller with hinge lip PS

4.2 W-frame

The dock leveller framing is welded to the previously prepared initial frame fastened in the building floor. This solution allows you to install the leveller after completing concrete works. Potential and easy replacement of the device in future is an additional advantage.

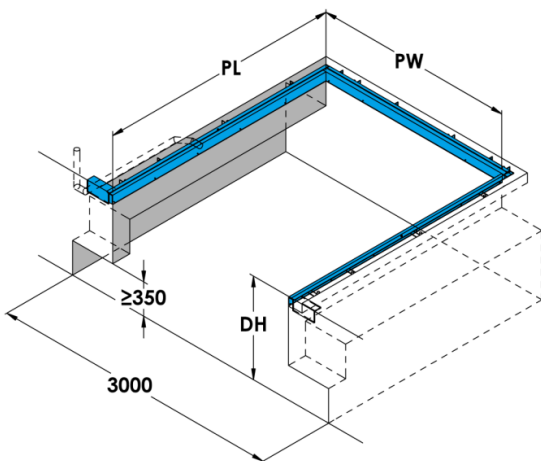
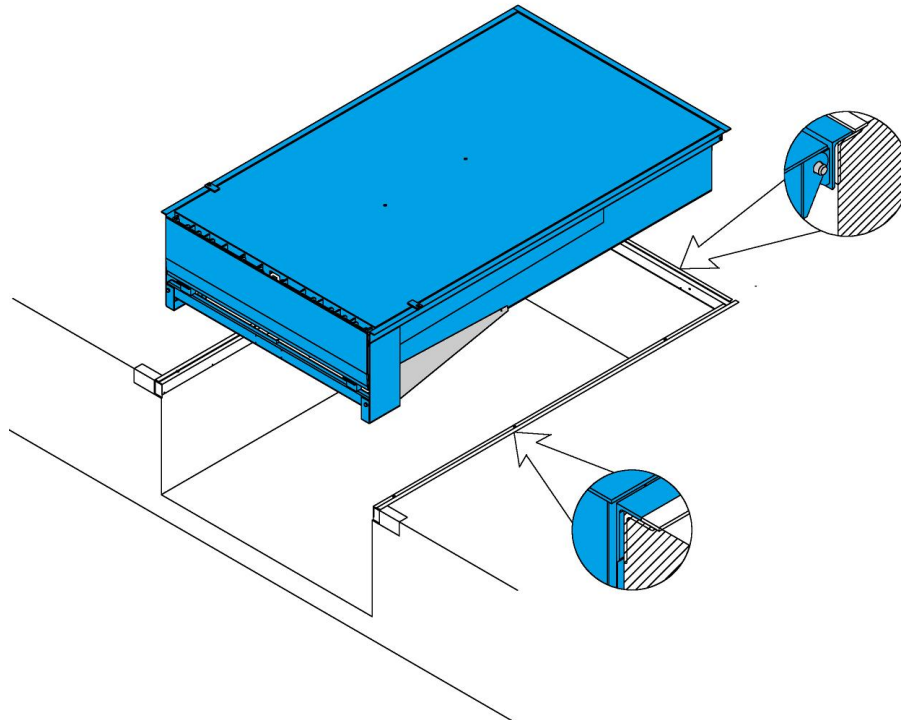

PSE.00.00.01

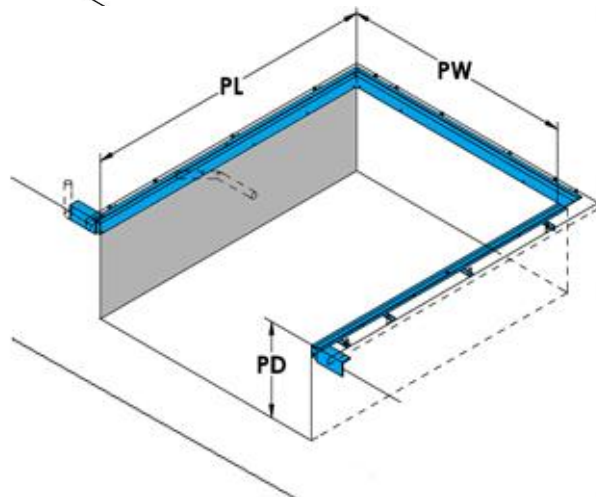

PSE.00.00.05

Dock leveller with hinge lip PS

4.3 F-frame

The dock leveller framing is welded to the existing frame. With this design, the platform can be installed in a pit from which the old platform has been removed.

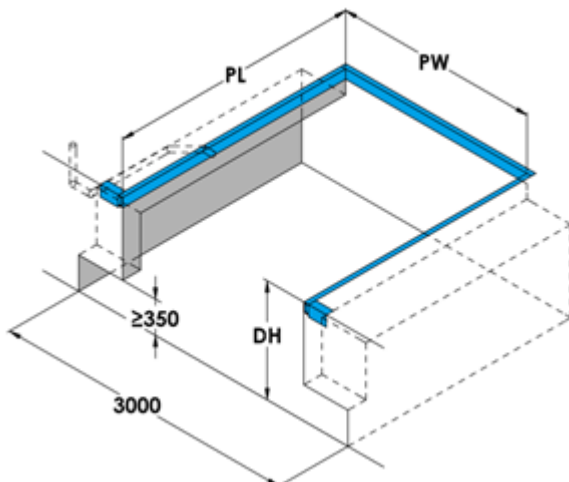
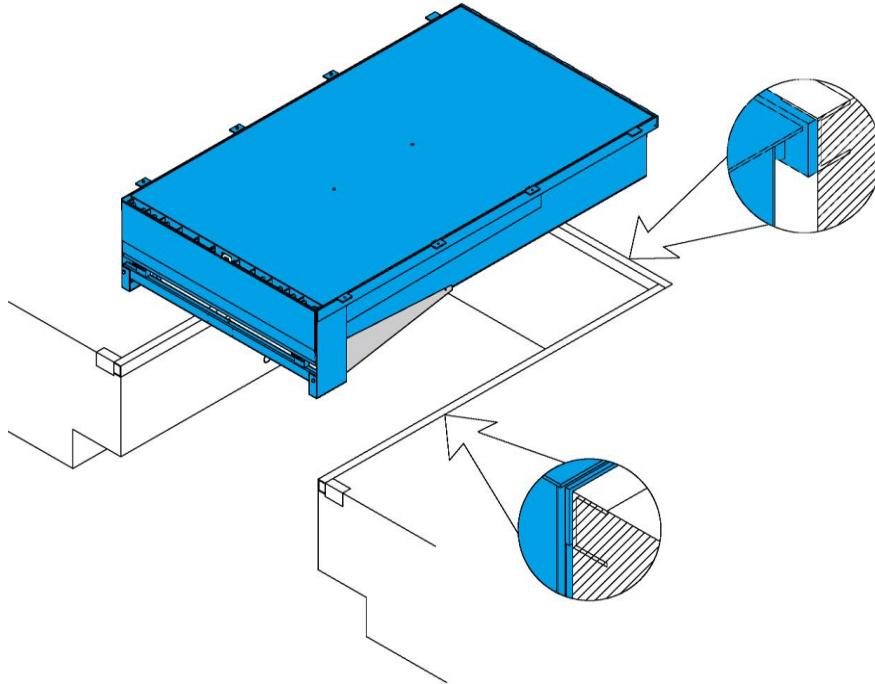

PSE.00.00.02

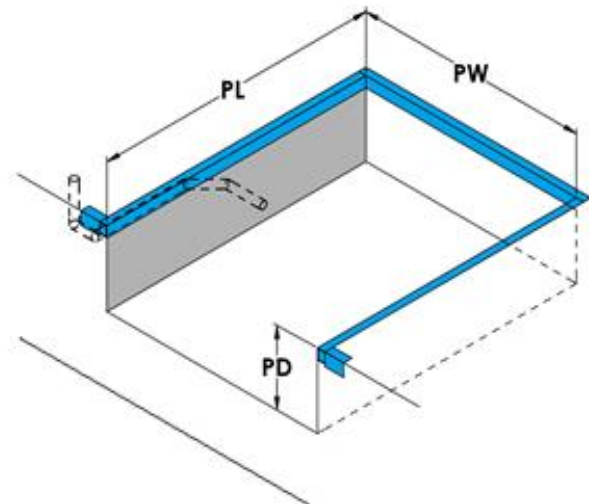

PSE.00.00.07

4.4 O-frame

The dock leveller framing is welded directly to a properly prepared initial frame in a pit made of angle bars and sheets. The advantage of this solution is reduction of the cost of purchasing the device and the possibility to install the platform after completion of concrete works.

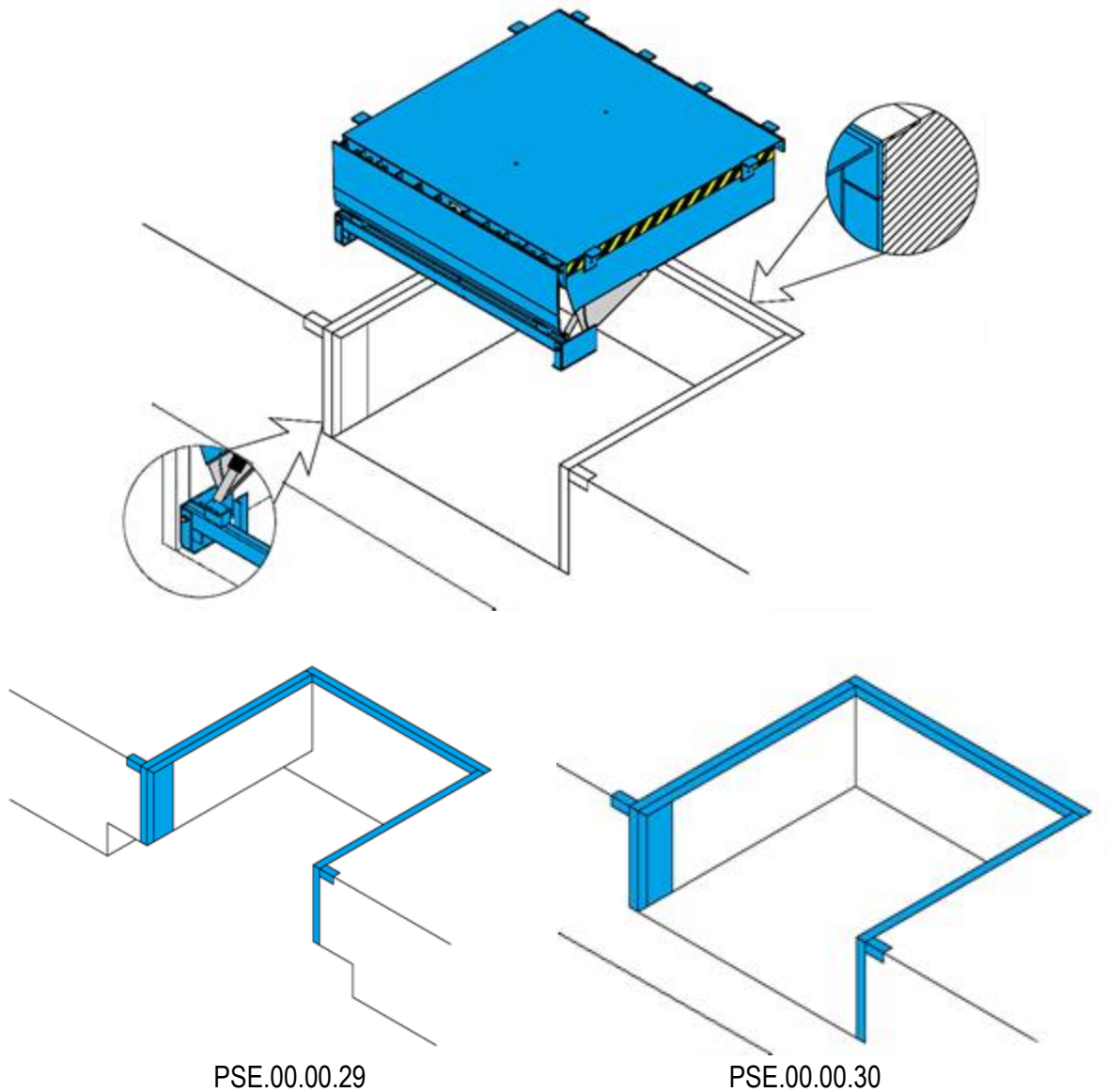

4.5 B-frame

The dock leveller framing is filled with concrete. The frame around the leveller serves as a formwork. Since no complex formworks are required to be used, this solution considerably facilitates civil works and reduces costs.

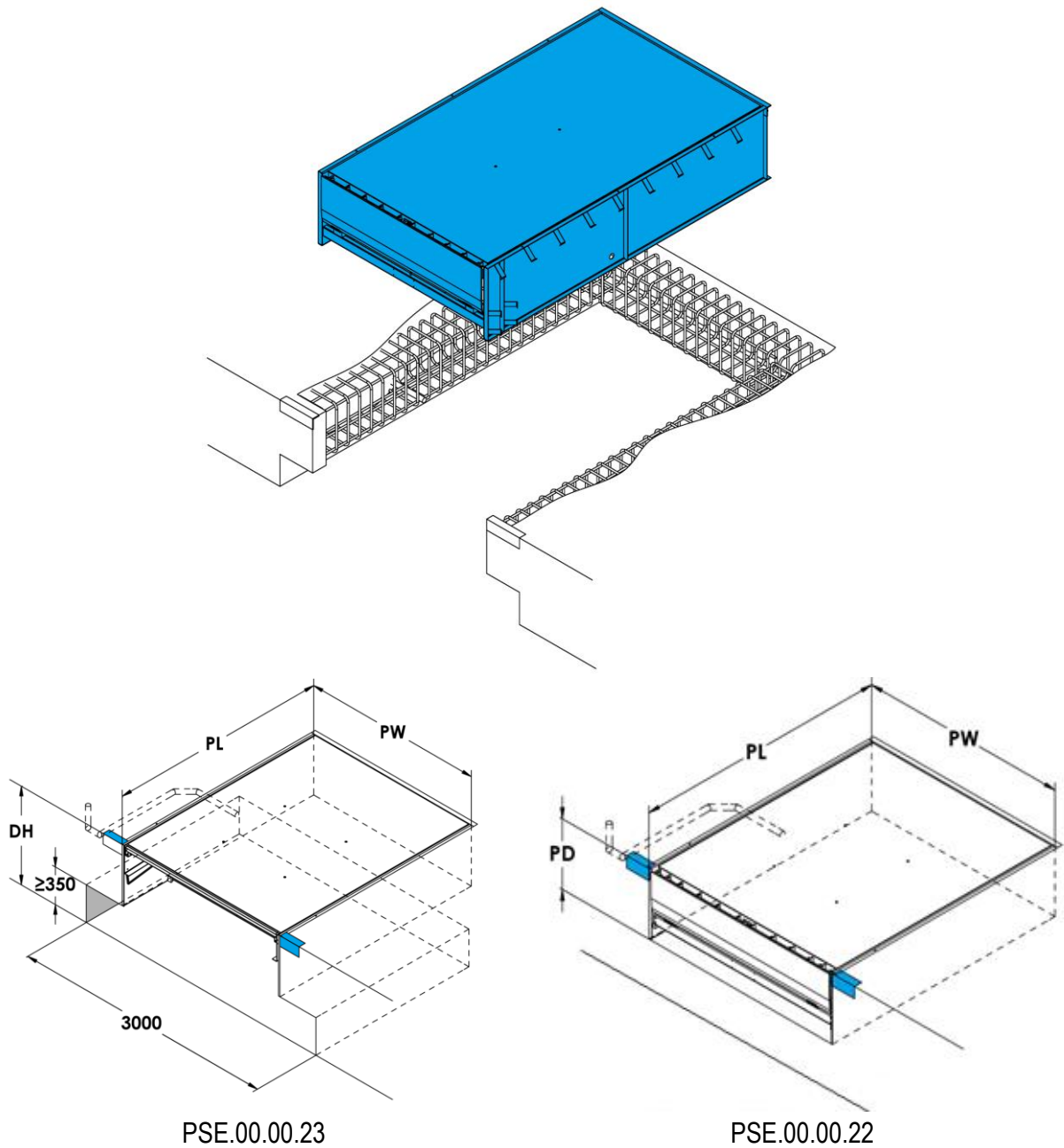

4.6 Pit-frame

The dock leveller framing is welded to the angle at the back of the pit. The platform is located at the bottom of the pit. The advantage of this solution is easy and quick assembly.

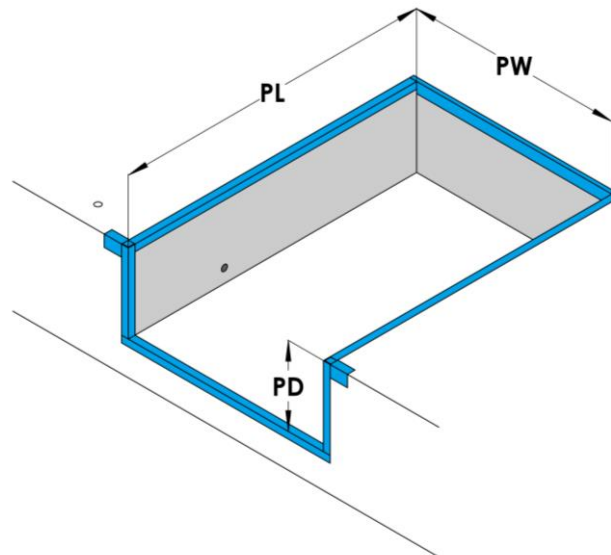
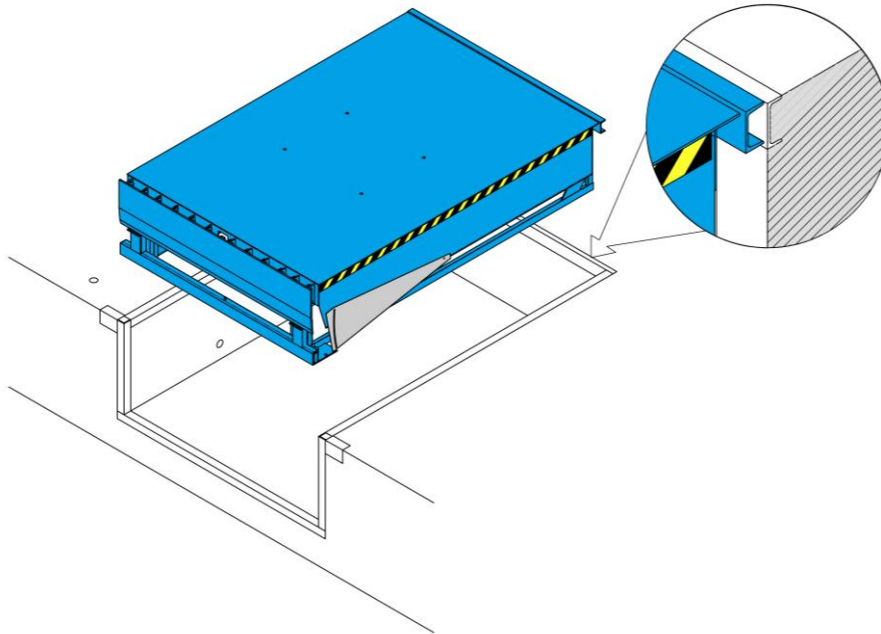

PSE.00.00.06

4.7 SMD-frame

The dock leveller framing is welded to the angle at the back and at the front of the pit (pit without tail lift) or to the supporting beam at the front of the pit (pit with tail lift).

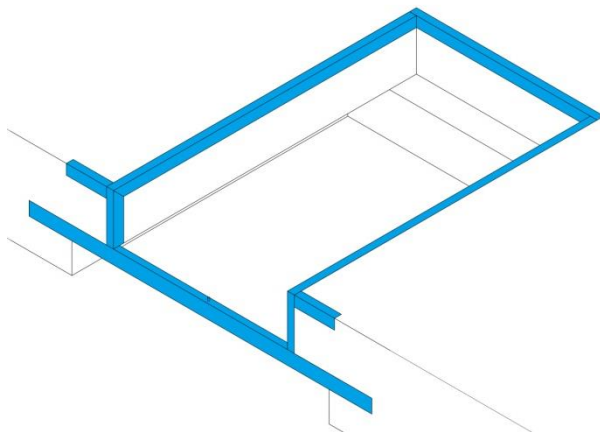
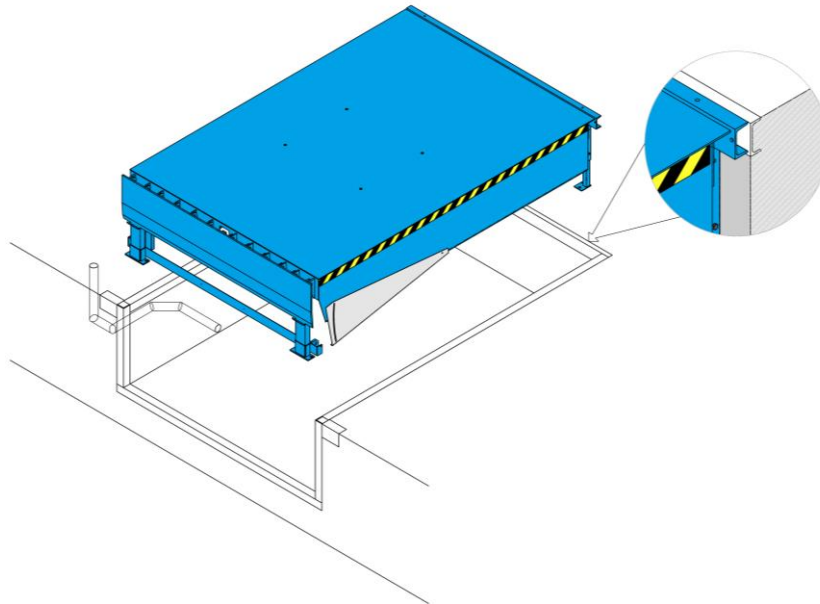



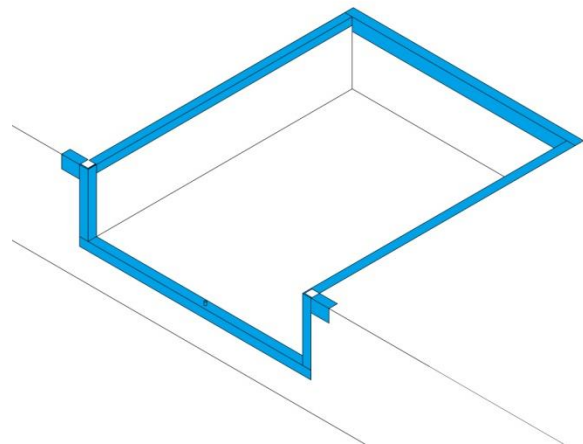

SMART.00.00.02



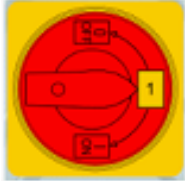

SMART.00.00.01

5. Control system

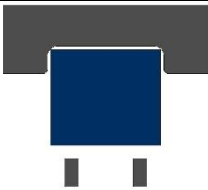
The control system of the PS-type dock leveller manufactured by PROMStahl is available in two versions: standard and equipped with a series of auxiliary options supporting operation of additional devices, accessories and sensors.

	<p style="text-align: center;">Main switch</p> <p>It is used for switching the device on/off every day and serves as an emergency switch. Switching the main switch stops all movements of the device.</p>
	<p style="text-align: center;">Control button</p> <p>For lifting the platform, swinging the lip to the working position and causing the dock leveller to return to home position.</p>
	<p style="text-align: center;">Automatic return button</p> <p>Brief push of this button causes the dock leveller to automatically return from working to home position.</p>
	<p style="text-align: center;">Air sealing control</p> <p>This button allows you to control the air sealing manually. It is also possible to connect sealing in an automatic way ensured by the dock leveller or door.</p>
	<p style="text-align: center;">Sealing blind control</p> <p>The controller makes it possible to connect the sealing blind motor and additional buttons are used for lifting and lowering the blind.</p>

Dock leveller with hinge lip PS

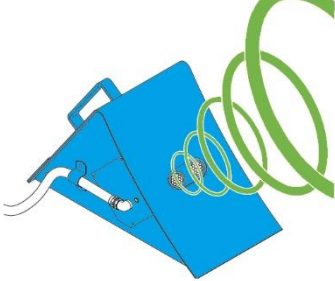
	<p style="text-align: center;">PROM door control</p> <p>Additional buttons for controlling the functions of the PROM door from the control panel of the dock leveller.</p>
	<p style="text-align: center;">LCD</p> <p>Display with additional servicing and diagnostic functions.</p>
<p style="text-align: center;">The control system of the dock leveller allows you to connect other safety accessories.</p>	
	<p style="text-align: center;">Indicator lights</p> <p>Connection of indicator lights (internal and external) for better safety of works.</p>
	<p style="text-align: center;">Wheel chock sensor</p> <p>A wheel chock makes it impossible to activate the dock leveller before securing the docked vehicle (it prevents the vehicle from moving away during loading operations).</p>

Dock leveller with hinge lip PS

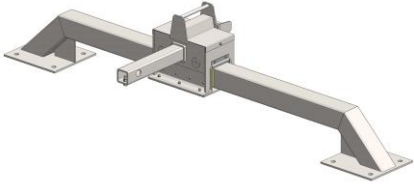
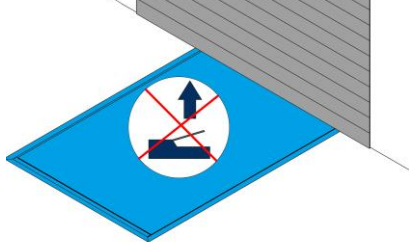
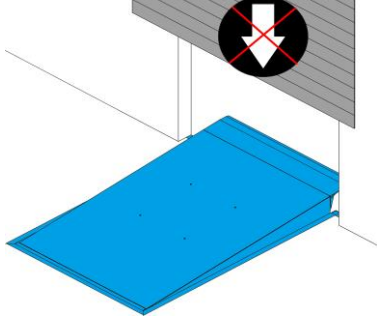
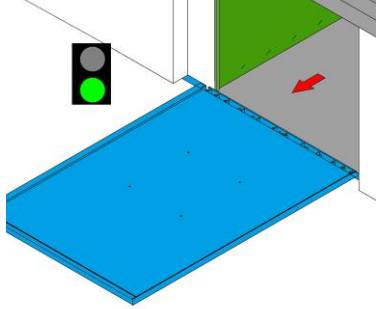
	<p style="text-align: center;">Mechanical wheel lock</p> <p>The mechanical wheel lock prevents the vehicle from moving away and makes it impossible to activate the dock leveller before securing the docked vehicle.</p>
	<p style="text-align: center;">Door sensor</p> <p>The door sensor makes it impossible to activate the dock leveller before opening the door (it prevents door and leveller collision).</p>
	<p style="text-align: center;">Door release signal</p> <p>An additional connector with a door lock signal when the dock leveller is not in its home position. It prevents door and leveller collision.</p>
	<p style="text-align: center;">Vehicle sensor</p> <p>The controller allows you to connect an optical sensor detecting a docked vehicle.</p>

Dock leveller with hinge lip PS

	BASIC type controller*	PBES 1MV 06*	PBES 1MV 07	PBES 1MV 08*	PBES 1MV 09*	PBES 1MV 11
		Automatic return	✘	✓	✓	✓
Air sealing control - automatic	✘	✓	✓	✓	✓	✘
Air sealing control – automatic + button	✘	✘	✘	✓	✓	✘
Sealing blind control	✘	✓	✓	✓	✓	✘
Door control buttons	✘	✓	✘	✘	✓	✘
Indicator light control	✘	✓	✓	✓	✓	✘
Door sensor	✓	✓	✓	✓	✓	✓
Wheel chock sensor	✓	✓	✓	✓	✓	✓
Mechanical wheel lock sensor	✘	✓	✓	✓	✓	✘
Vehicle sensor	✘	✓	✓	✓	✓	✘
Leveller position sensor	✘	✓	✓	✓	✓	✘

✓ - support

✘ - no support

* controller available on request after prior consultation with a PROMStahl representative

6. Leveller selection

Nominal capacity

This is the maximum loading value resulting from the total weight of objects moved on the dock leveller. According to the guidelines of EN 1398 standard this value takes into consideration dynamic effects caused by the operated forklift truck. The total weight of the used forklift truck with accessories, the driver and the load must not exceed the nominal loading capacity of the dock leveller.

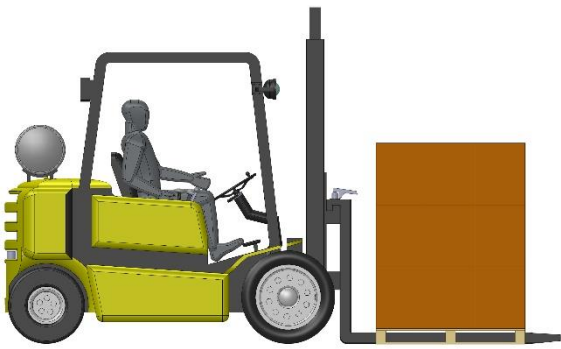
	<table> <tr> <td>Forklift truck</td> <td>3600 kg</td> </tr> <tr> <td>Weight of transported goods</td> <td>1500 kg</td> </tr> <tr> <td>Operator's weight</td> <td>100 kg</td> </tr> <tr> <td>Total weight</td> <td>$\Sigma=5200 \text{ kg} < 6000\text{kg}$ = 60 kN</td> </tr> </table>	Forklift truck	3600 kg	Weight of transported goods	1500 kg	Operator's weight	100 kg	Total weight	$\Sigma=5200 \text{ kg} < 6000\text{kg}$ = 60 kN
Forklift truck	3600 kg								
Weight of transported goods	1500 kg								
Operator's weight	100 kg								
Total weight	$\Sigma=5200 \text{ kg} < 6000\text{kg}$ = 60 kN								

Wheel pressure

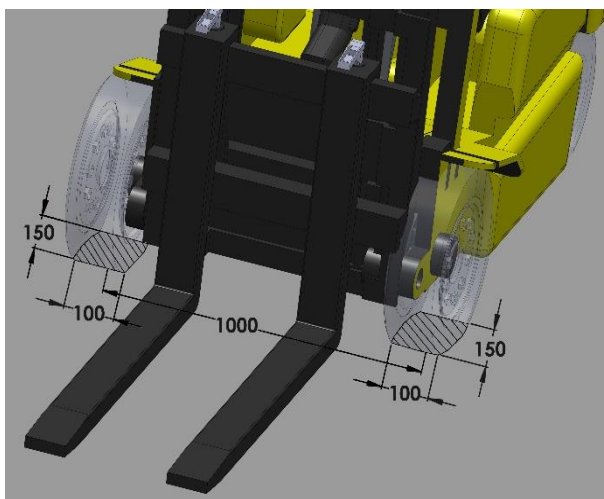

According to the guidelines of EN 1398 standard, the basic version of the dock leveller was designed for works with forklift truck with pneumatic or super elastic wheels with tread resembling two 150 mm x 100 mm rectangles. For devices with hard wheels (e.g. electric pallet trucks), please consult a representative of PROMStahl to select the best solution for your docking station.

Dock leveller with hinge lip PS

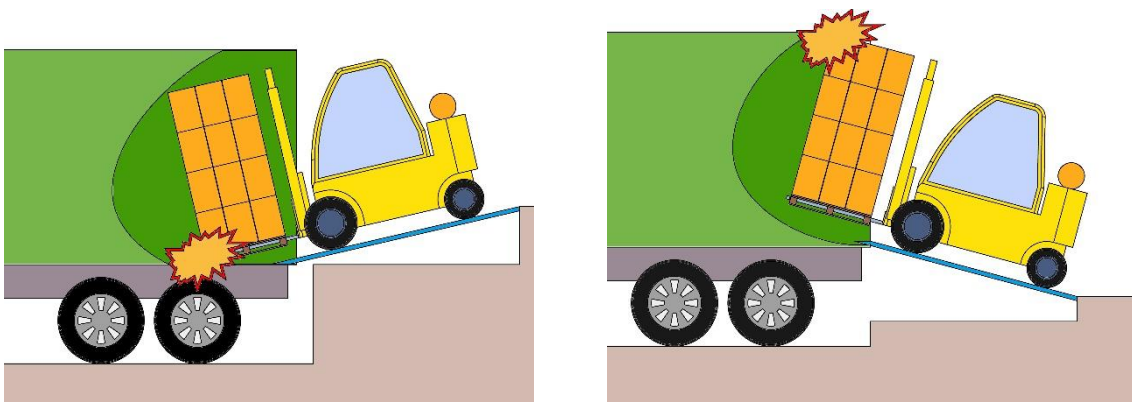

Nominal length

Nominal length of the applied dock leveller and maximum height differences between the warehouse floor and the vehicle deck determine the slope of the platform in its working position. The slope value should not exceed maximum recommended values for given loading devices. The maximum permissible value recommended by EN 1398 is 12.5%. Too much inclination may damage transported goods, cause the docking device to be hanged and decrease the durability of the dock leveller (greater travel dynamics).

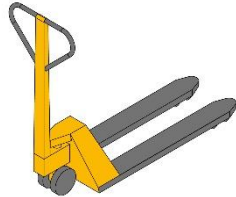
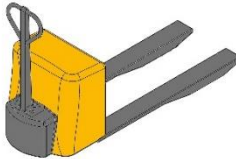

Docking device		Maximum recommended slope
Small hand-operated devices, e.g. pallet truck		3 ÷ 5 %
Small electrically-driven devices, e.g. electric pallet truck		7 %



Dock leveller with hinge lip PS

Electric forklift trucks		<p>10 %</p>
Engine-powered forklift trucks		<p>12.5 %</p>

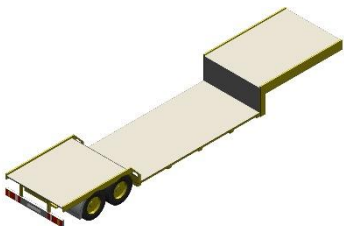
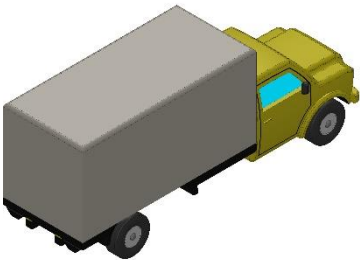
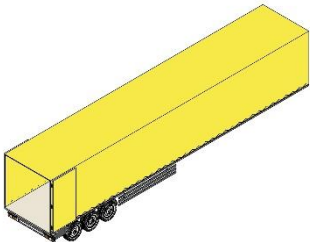
Estimated heights of trucks:

	Type of vehicle	Deck height [mm]
Low-loading semi-trailers		<p>600 - 1000</p>
Commercial vehicles		<p>1000 - 1200</p>
Semi-trailers		<p>1100 - 1400</p>

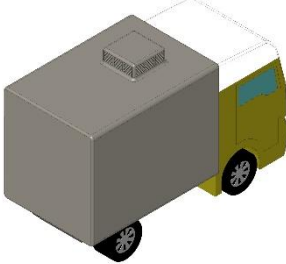
Dock leveller with hinge lip PS

Refrigerated trucks		1300 - 1500
Containers		1200 - 1600

Example:

Docking device: electric forklift truck (maximum slope: 7%)

Vehicle deck height: 1100 mm – 1400 mm

Building floor height: 1200 mm

Maximum height difference to be compensated: 200 mm

$200 \text{ mm} / 7\% = 2857 \text{ mm}$ → the minimum nominal length NL = 3000 mm has to be taken

Nominal width

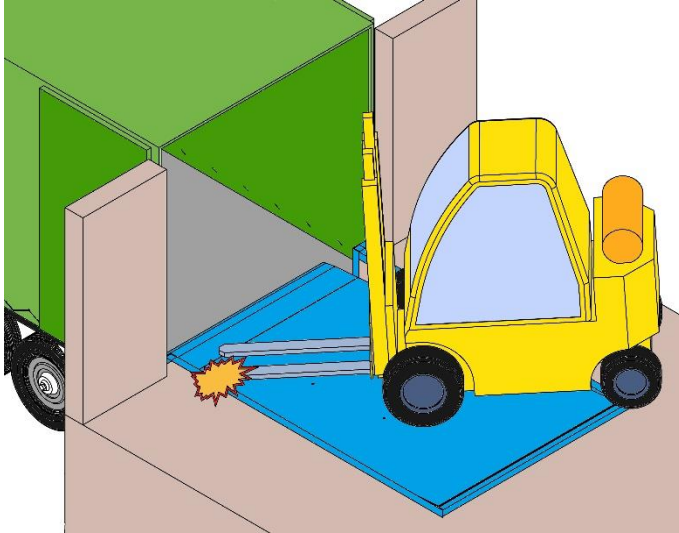

Pursuant to the guidelines of EN 1398 standard, the minimum width of a dock leveller is related to the width of used docking devices and should be greater by at least 700 mm than their tread. Failure to meet this condition may compromise the loading safety (when reloading above the floor) or limit the efficiency (when reloading below the floor).

Example:

Tread of the widest docking device is 1200 mm

$1200 \text{ mm} + 700 \text{ mm} = 1900 \text{ mm} \rightarrow$ the minimum nominal width $NW = 2000 \text{ mm}$ has to be taken

The maximum width of a dock leveller is related to the width of the vehicle deck and docking accuracy. When determining the maximum width of the vehicle, take into account the width of the deck of the narrowest vehicle and reduce it by the recommended docking inaccuracy tolerance (recommended 150 mm per side). The maximum width value can be increased by side segments of the lip.

Example:

The deck of the narrowest vehicle has 2450 mm in width.

$2500 \text{ mm} - 2 \cdot 150 \text{ mm} = 2150 \text{ mm} \rightarrow$ the maximum nominal widths $NW = 2100 \text{ mm}$ for standard lip or 2250 mm for lip with side segments (2 x 125 mm) are to be taken.

Maximum height of the dock leveller

The maximum height of the dock leveller results from maintaining a tail-lift recess (undercut). This is a place under the dock leveller of the following minimum, recommended dimensions: 3000 mm x 350 mm. The tail-lift recess is necessary for docking vehicles with a lift.

Dock leveller with hinge lip PS

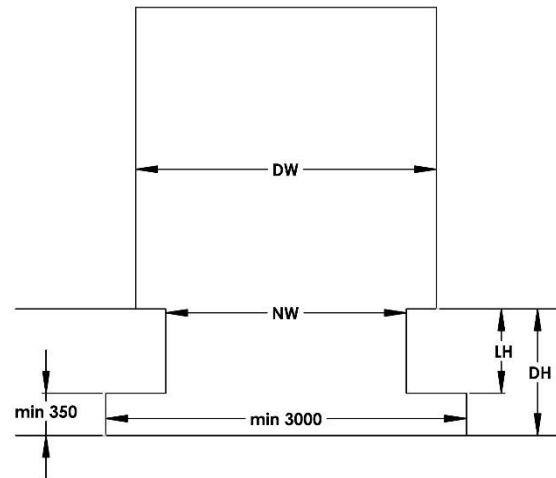
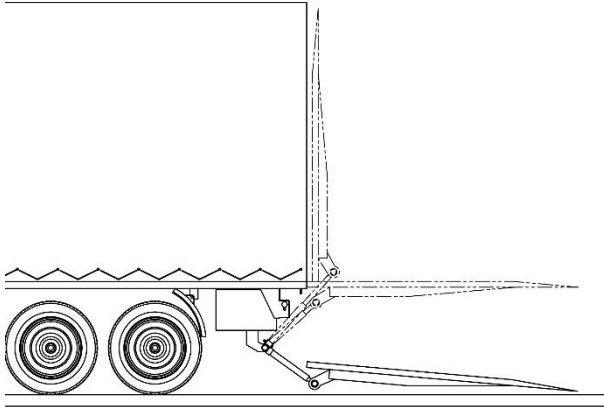

NW – nominal width of the dock leveller

LH – leveller height

DH – dock height

DW – door width

Taking the leveller height away from the dock height gives the height of the tail-lift recess.

Example:

Dock height: 1100 mm

Leveller height: 700 mm

$1100 - 700 = 400 > 350 \rightarrow$ the minimum height of the tail-lift recess is ensured.