

400
VOLT

GATE OPERATOR

BIG 18QI

For gates up to 2500 Kg

500BIG18QI

400 V three-phase sliding gate operator complete with electronic control unit. Maximum gate weight 2500 kg. STAINLESS STEEL housing.

See page 25 for accessories

Features:

- commercial use
- for gates up to 2500 kg
- 400 V three-phase gate operator
- STAINLESS STEEL housing
- manual release mechanism
- adjustable mechanical clutch

Pros:

- suitable for large sliding gates
- high torque and power thanks to the three-phase technology
- self-ventilated operator to increase the working cycle
- metal and bronze gears to increase endurance and reduce noise

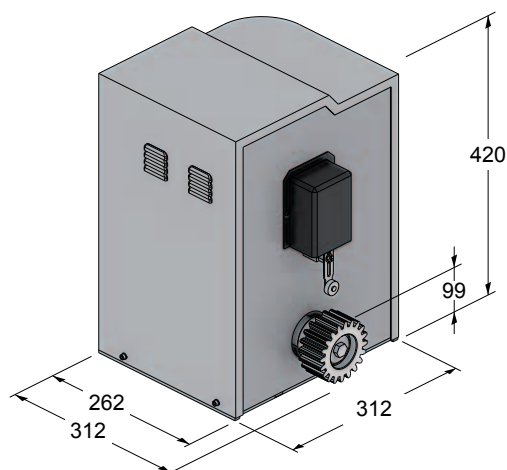

Technical features

	BIG18QI
Power supply	400 V AC (50 - 60 Hz)
Motor power supply	400 V AC
Absorption	3 A
Absorbed power	1000 W
Speed maneuver	10 m/min
Duty cycle	55 %
Max. thrust	1850 N
Operating temperature	-20° C + +55° C
Motor thermal protection	150° C
Degree of protection	IP 44
Max. gate leaf weight	2500 kg
Pinion module	Module 4



The above represented installation does not include safety devices such as safety edges. Their addition depends upon the risk assessment made on any installation in accordance with EN 12445-12453 standards.



OPERATOR BIG 30Q

**400
VOLT**

For gates up to 3000 Kg

500BIG30Q

400 V three-phase sliding gate operator complete with electronic control unit. Maximum gate weight 3000 kg.

See page 25 for accessories

Technical features

BIG30Q

Power supply	400 V AC (50 - 60 Hz)
Motor power supply	400 V AC
Absorption	3,6 A
Absorbed power	1500 W
Speed maneuver	12,5 m/min
Work cycle	50 %
Max. thrust	3500 N
Operating temperature	-20° C ÷ +55° C
Motor thermal protection	150° C
IP protection level	IP 44
Max. gate leaf weight	3000 kg
Pinion module	Module 4

Features:

- commercial use
- for gates up to 3000 kg
- 400 V three-phase gate operator
- oil bath vertical pinion operator
- painted steel housing
- manual release mechanism
- mechanical clutch for crush prevention

Pros:

- suitable for large sliding gates
- high torque and power thanks to the three-phase technology
- self-ventilated operator to increase the working cycle
- metal and bronze gears to increase endurance and reduce noise



The above represented installation does not include safety devices such as safety edges. Their addition depends upon the risk assessment made on any installation in accordance with EN 12445-12453 standards.

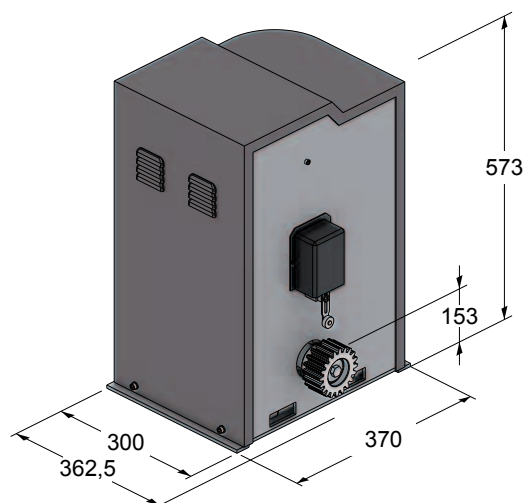

400
VOLT

GATE OPERATOR

BIG 40Q

For gates up to 4000 Kg

500BIG40Q

400 V three-phase sliding gate operator for intensive use complete with electronic control unit and "soft-start". Maximum gate weight 4000 kg.

Features:

- commercial use
- for gates up to 4000 kg
- 400 V three-phase gate operator
- oil bath vertical pinion operator
- soft start acceleration ramp and soft stop
- manual release mechanism
- Module 6 rack pinion version available upon request
- mechanical clutch for crush prevention

Pros:

- suitable for huge sliding gates
- high torque and power thanks to the three-phase technology
- self-ventilated operator to increase the working cycle
- metal and bronze gears to increase endurance and reduce noise
- intensive use (50% working cycle)



Technical features

BIG40Q

Power supply	400 V AC (50 - 60 Hz)
Motor power supply	400 V AC
Absorption	3,6 A
Absorbed power	1500 W
Max. operating speed	12,5 m/min
Duty cycle	50 %
Max. thrust	3500 N
Operating temperature	-20° C + +55° C
Motor thermal protection	150° C
Degree of protection	IP 44
Max. gate leaf weight	4000 kg
Pinion module	Module 4

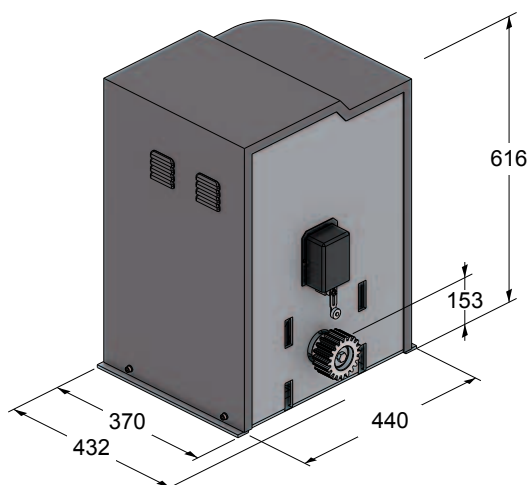

The above represented installation does not include safety devices such as safety edges. Their addition depends upon the risk assessment made on any installation in accordance with EN 12445-12453 standards.

Accessories for "BIG" series of Sliding Gate Operators



400CP12
BIG18QI counterplate



S-600D703M00
230/400 V replacement
electronic control unit for
one gate operator with
electrical brake



400CP30
BIG30Q counterplate



400CFZ22
Steel rack 22x22 (Module 4,
max 3000 kg)



400CP40
BIG40Q counterplate

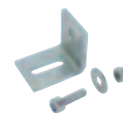

400VSF20
Screws and brackets for
400CFZ22 (40 units per
pkg)



900KITCF
Safety edge kit 2 m.

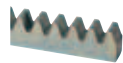

550CFZ06
Steel rack 30x30 (Module 6,
max 4000 kg)

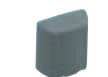

900TWC
Wireless safety edge
transmitter



C-TARG
Aluminium CE mark label,
self adhesive

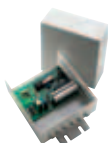

900TWM
Wireless safety edge
master receiver



750COL
Control unit mounting post



C-CRT
Warning signal



250RXDC1
Self-learning, single-channel,
433,92 MHz plug-in radio
receiver. Accepts up to 62
rolling code transmitters
or unlimited dipswitch
transmitters.



Further accessories:
Transmitters page 106
Photocells page 112
Flashing lights page 115