

**12**  
VOLT

# GATE OPERATOR R18 BENC

For gate leaves up to 1,8 m



## 650R18BENC

DC electromechanical gate operator with encoder. Maximum gate leaf 1,8 m (foundation box to be ordered separately) with **cabl** l=2,3 m.

## 650R18BENCL

**NEW**

DC electromechanical gate operator with encoder. Maximum gate leaf 1,8 m (foundation box to be ordered separately) with **cabl** l=5 m.

## 650R18BENCVEL

DC fast electromechanical gate operator with encoder. Maximum gate leaf 1,2 m / 200 kg (foundation box to be ordered separately) with **cabl** l=2,3 m.

### Features:

- residential use
- for gates leaves up to 1,8 m
- low voltage DC gate operator
- optical encoder technology
- electromechanical motor

### Pros:

- compact size
- virtually invisible, does not affect the design of the gate
- opening up to 360° with no additional accessories
- obstacle detection and crush prevention
- in accordance with EN 12445-12453 standards
- works even during power outage thanks to the optional backup battery
- fast operating speed
- intensive use, ideal for use on apartment buildings and public entrances



### Watertight

The new watertight collar diverts rain water ensuring a complete and lasting protection.



### Opening up to 360°

The compact R18 gate operator is ideal where opening space is an issue

### Technical features

	R18BENC/L	R18BENCVEL
Power supply	230 V AC (50 - 60 Hz)	230 V AC (50 - 60 Hz)
Motor power supply	18 V DC	18 V DC
Open circuit voltage	0,7 A	0,8 A
Power rating	120 W	120 W
Opening time 90°	13 sec.	9 sec.
Duty cycle	100 %	100 %
Max. torque	192 Nm	180 Nm
Operating temperature	-20° C ÷ +55° C	-20° C ÷ +55° C
Motor thermal protection	-	-
Degree of protection	IP 67	IP 67

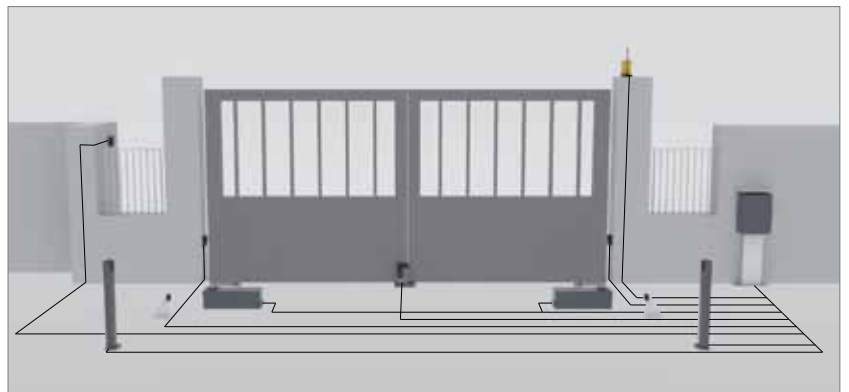

The above represented installation does not include safety devices such as safety edges. Their addition depends upon the risk assessment made on any installation in accordance with EN 12445-12453 standards.



**INSIDEKIT04A**

Complete underground automation kit for gates up to 1,8 + 1,8 m, with two 650R18BENC gate operators (1 with cable l=2,3 m + 1 with cable l=5 m)

**Accessories included in the kit (foundation boxes to be ordered separately):**



900OPTIC



750D749MA



300T-KEY  
aluminium +  
LED TSL



250ANTD



900LAMP4



250K-SLIMRP



C-CRT

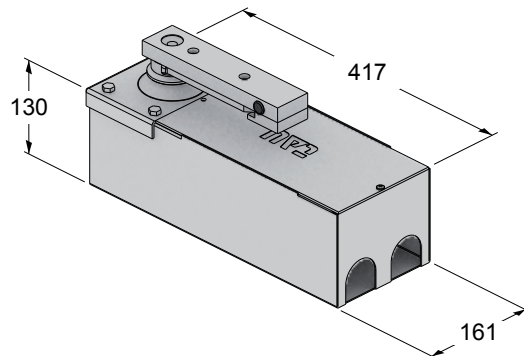

**Accessories**



700CFR18CT  
Cataphoresis steel  
foundation box **with release system**



200BATT  
12 Volt Battery, 7,2 Ah  
with cable



700CFR18X  
Stainless steel foundation  
box **with release system**



M-030KITKB20  
Battery cables kit (20 pcs)



700BRC18  
R18 Retrofit adapter arm



700GS5  
Weatherproof cable  
connector for 5-core 12 V  
cable



750D749MA  
Electronic control unit for one  
or two DC gate operators with  
encoder, complete with 433,92  
Mhz rolling code radio receiver,  
battery charger, transformer and  
enclosure



650ESV1-2  
Electric lock (1 = left hand  
opening – 2 = right hand  
opening)



M-030000CC50  
Multicore cable (2 x 2.5  
sq.mm + 3 x 0.5 sq.mm)



C-TARG  
Aluminium CE Mark Label,  
self adhesive



250SM126  
Memory card for 126 radio  
codes

**NEW**



250SM254  
Memory card for 254 radio  
codes

**NEW**

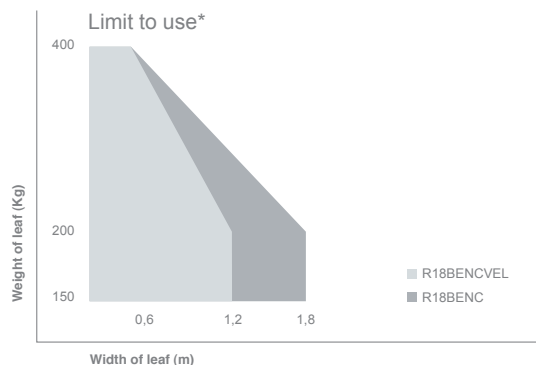

\*They refer to leaves with openings and not totally closed panels.

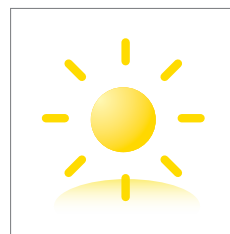

**Solar power**  
Thanks to the Photovoltaic (PV) Technology, every low voltage DC gate operator can be solar powered. Discover the advantages of the solar energy at page 130



**Further accessories:**  
Transmitters page 110  
Photocells page 116  
Flashing lights page 119

⚠ Use only M-030000CC50 cable or equivalent

**230**  
VOLT

# GATE OPERATOR R18

For gate leaves up to 1,8 m



## 650R18

230 V electromechanical gate operator. Maximum gate leaf 1,8 m (foundation box to be ordered separately) with **cabl e l=2,3 m**.

## 650R18L

**NEW**

230 V electromechanical gate operator. Maximum gate leaf 1,8 m (foundation box to be ordered separately) with **cabl e l=5 m**.

### Features:

- residential use
- for gates leaves up to 1,8 m
- 230 V gate operator
- electromechanical motor

### Pros:

- compact size
- virtually invisible, does not affect the design of the gate
- opening up to 360° with no additional accessories
- manual release
- high torque and power

### Technical features

	<b>R18/L</b>
Power supply	230 V AC (50 - 60 Hz)
Motor power supply	230 V AC
Absorption	1,3 A
Power rating	240 W
Opening time 90°	22 sec.
Duty cycle	32 %
Max. torque	148 Nm
Operating temperature	-20° C + +55° C
Motor thermal protection	160° C
Degree of protection	IP 67



### Watertight

The new watertight collar diverts rain water ensuring a complete and lasting protection.



### Opening up to 360°

The compact R18 gate operator is ideal where space is an issue

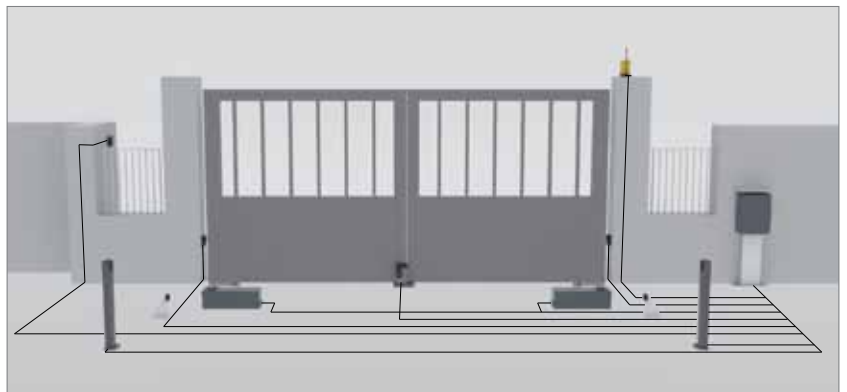

The above represented installation does not include safety devices such as safety edges. Their addition depends upon the risk assessment made on any installation in accordance with EN 12445-12453 standards.



**INSIDEKIT05T**

Complete underground automation kit for gates up to 1,8 + 1,8 m, with two 650R18 gate operators (1 with cable l=2,3 m + 1 with cable l=5 m)

Accessories included in the kit (foundation boxes to be ordered separately):

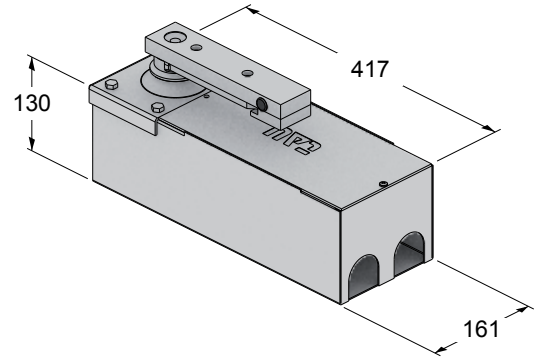

**Accessories**

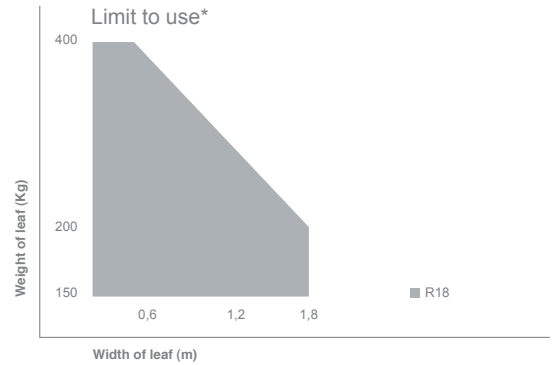

\*They refer to leaves with openings and not totally closed panels.



**Further accessories:**  
Transmitters page 110  
Photocells page 116  
Flashing lights page 119