

12
VOLT

GATE OPERATOR ARM BI

For gate leaves up to 5 m

650ARM225BI

DC electromechanical linear gate operator with encoder. Maximum gate leaf 3 m.

650ARM250BI

DC electromechanical linear gate operator with encoder. Maximum gate leaf 4 m.

650ARM270BI

DC electromechanical linear gate operator with encoder. Maximum gate leaf 5 m.

Features:

- residential / apartment building / commercial use
- for gates leaves up to 5 m
- low voltage DC gate operator
- optical encoder technology
- rod extension gate operator
- adjustable mounting brackets (sold separately)

Pros:

- obstacle detection and crush prevention
- in accordance with EN 12445-12453 standards
- works even during power outage thanks to the optional backup battery
- fast operating speed
- soft start and soft stop
- intensive use, ideal for use on apartment buildings and public entrances
- electrical connections are easier thanks to the larger upper space
- quick and easy installation
- suitable for large gates and non standard sized posts



Easy mounting

Multi-position adjustable brackets allow greater flexibility during assembly even on non standard sized posts (sold separately)



Manual release with personal key

Easy-to-operate manual release with key lock for the less skilled users

Technical features	ARM225BI	ARM250BI	ARM270BI
Power supply	230 V AC (50 - 60 Hz)	230 V AC (50 - 60 Hz)	230 V AC (50 - 60 Hz)
Motor power supply	18 V DC	18 V DC	18 V DC
Open circuit voltage	1 A	1 A	1 A
Power rating	120 W	120 W	120 W
Opening time 90°	12 sec.	12,5 sec.	13 sec.
Duty cycle	100 %	100 %	100 %
Max. thrust	2600 N	2600 N	2600 N
Operating temperature	-20° C ÷ +55° C	-20° C ÷ +55° C	-20° C ÷ +55° C
Motor thermal protection	-	-	-
Degree of protection	IP 44	IP 44	IP 44

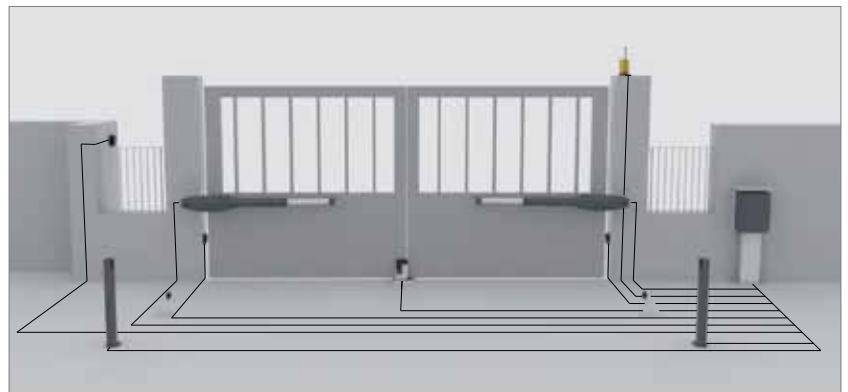

The above represented installation does not include safety devices such as safety edges. Their addition depends upon the risk assessment made on any installation in accordance with EN 12445-12453 standards.



KARM225BI

Complete double arm automation kit for gates up to 3 + 3 m, with two 650ARM225BI gate operators

KARM250BI

Complete double arm automation kit for gates up to 4 + 4 m, with two 650ARM250BI gate operators

KARM270BI

Complete double arm automation kit for gates up to 5 + 5 m, with two 650ARM270BI gate operators

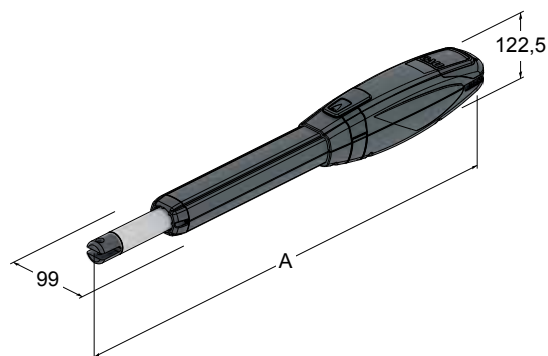

Accessories included in the kit:



900OPTIC



750D749MA



300T-KEY
aluminium +
LED TSL



250ANTD



900LAMP4



250K-SLIMRP



C-CRT

	A
ARM225BI	811
ARM250BI	951
ARM270BI	1056

Accessories



750D749MA
Electronic control unit for one or two DC gate operators with encoder, complete with 433,92 Mhz rolling code radio receiver, battery charger, transformer and enclosure



650ESV1-2
Electric lock (1 = left hand opening – 2 = right hand opening)



200BATT
12 Volt Battery, 7,2 Ah



700BAP
Gate stopper for heavy leaves



M-030KITKB20
Battery cables kit (20 pcs)



700GS5
Weatherproof cable connector for 5-core 12 V cable



M-030000CC50
Multicore cable (2 x 2.5 sq.mm + 3 x 0.5 sq.mm)



C-TARG
Aluminium CE Mark Label, self adhesive



250SM126
Memory card for 126 radio codes



P-650ARMKITSTF
Multi-position adjustable brackets

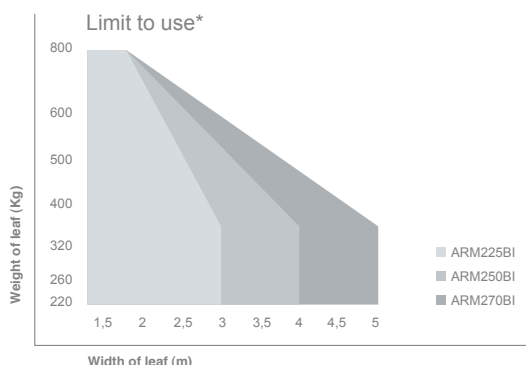

*They refer to leaves with openings and not totally closed panels.

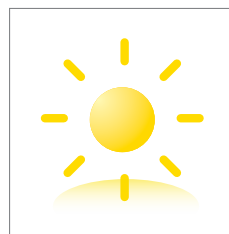

Solar power
Thanks to the Photovoltaic (PV) Technology, every low voltage DC gate operator can be solar powered. Discover the advantages of the solar energy at page 130



Further accessories:
Transmitters page 110
Photocells page 116
Flashing lights page 119

⚠ Use only M-030000CC50 cable or equivalent

📄 See page 134 for assembly measurements and opening angle

230
VOLT

GATE OPERATOR

ARM 225I/250I/270I

For gate leaves up to 5 m



650ARM225I

230 V electromechanical linear gate operator.
Maximum gate leaf 3 m.

650ARM250I

230 V electromechanical linear gate operator.
Maximum gate leaf 4 m.

650ARM270I

230 V electromechanical linear gate operator.
Maximum gate leaf 5 m.

Features:

- residential / commercial use
- for gates leaves up to 5 m
- 230 V gate operator
- built-in capacitor
- rod extension gate operator
- adjustable mounting brackets (sold separately)

Pros:

- electrical connections are easier thanks to the larger upper space
- quick and easy installation
- manual release with key lock
- high torque and power
- suitable for large gates and non standard sized posts

Technical features	ARM225I	ARM250I	ARM270I
Power supply	230 V AC (50 - 60 Hz)	230 V AC (50 - 60 Hz)	230 V AC (50 - 60 Hz)
Motor power supply	230 V AC	230 V AC	230 V AC
Absorption	1,5 A	1,5 A	1,5 A
Power rating	280 W	280 W	280 W
Opening time 90°	20 sec.	20,5 sec.	21 sec.
Duty cycle	36 %	36 %	36 %
Max. thrust	2300 N	2300 N	2300 N
Operating temperature	-20° C ÷ +55° C	-20° C ÷ +55° C	-20° C ÷ +55° C
Motor thermal protection	160° C	160° C	160° C
Degree of protection	IP 44	IP 44	IP 44



Easy mounting

Multi-position adjustable brackets allow greater flexibility during assembly even on non standard sized posts (sold separately)



Exclusive design

The new shapes adapt to any type of gate and have been designed to simplify installation and maintenance

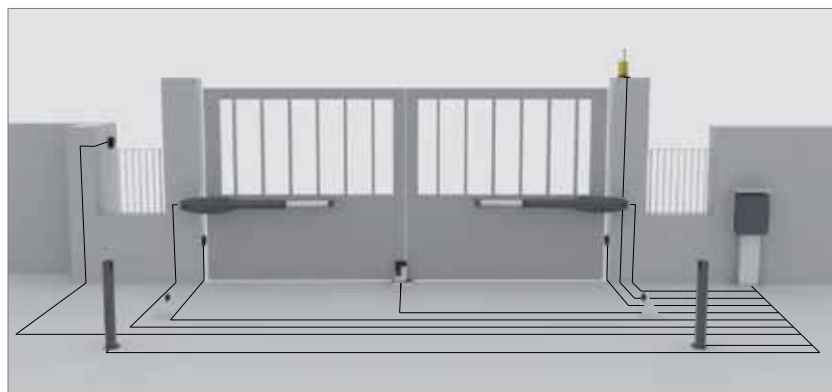

The above represented installation does not include safety devices such as safety edges. Their addition depends upon the risk assessment made on any installation in accordance with EN 12445-12453 standards.



KARM225I

Complete double arm automation kit for gates up to 3 + 3 m, with two 650ARM225I gate operators

KARM250I

Complete double arm automation kit for gates up to 4 + 4 m, with two 650ARM250I gate operators

KARM270I

Complete double arm automation kit for gates up to 5 + 5 m, with two 650ARM270I gate operators

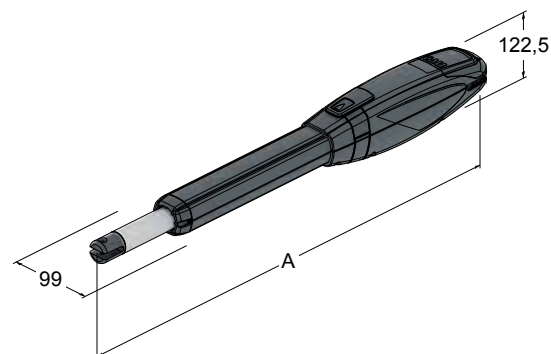

Accessories included in the kit:



900OPTIC



750D760M



300T-KEY
aluminium +
LED TSL



250ANTD



900LAMP3



250K-SLIMRP



C-CRT

Accessories



750D760M
Electronic control unit for one or two 230 V gate operators with soft-stop and built-in 433,92 MHz rolling code radio receiver, complete with enclosure



700BAP
Gate stopper for heavy leaves



750CUP
Control unit enclosure protective lid



700BAP1
Gate stopper for light leaves



700GS3
Weatherproof cable connector for 3-core 230 V cable



700BAP2
Gate stopper wall/floor mount



650ESV1-2
Electric lock (1 = left hand opening – 2 = right hand opening)



C-TARG
Aluminium CE Mark label, self adhesive



P-650ARMKITSTF
Multi-position adjustable brackets

	A
ARM225I	811
ARM250I	951
ARM270I	1056

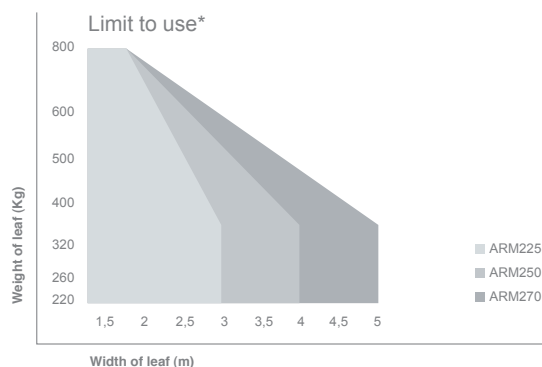

*They refer to leaves with openings and not totally closed panels.



Further accessories:
Transmitters page 110
Photocells page 116
Flashing lights page 119